



GENERAL INFORMATION



PAGE 134

8.1 TECHNICAL INFORMATION

8.2 APPLICATION EXAMPLES

PAGE 148

8.3 PRODUCT MATRIX

8.4 ORDER CODE

TECHNICAL INFORMATION

NADELLA TELESCOPIC SYSTEMS

Nadella telescopic slides are special ball bearing guides for high load rating. Two or more ball bearing mounted guide rails which can be drawn telescopic-wise guarantee a high reliability. According to the requirements a combination of different manufactured parts is used (rolled parts, cold-rolled steel and machined parts). Load and extension proportions are the basic characteristics of the telescopic slides. The model line is made up of five types and three extension proportions.

PART EXTENSIONS

extension length 50-70% of the assembly length

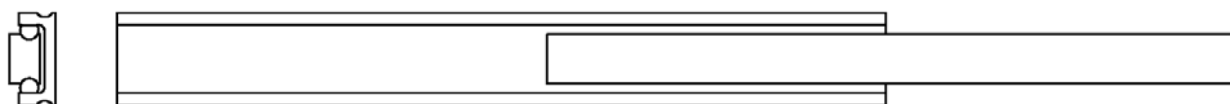

FULL EXTENSIONS

extension length 100% of the assembly length

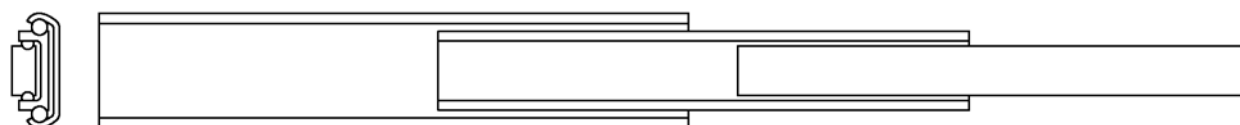

FULL EXTENSIONS IN Z DESIGN

extension length 100% of the assembly length

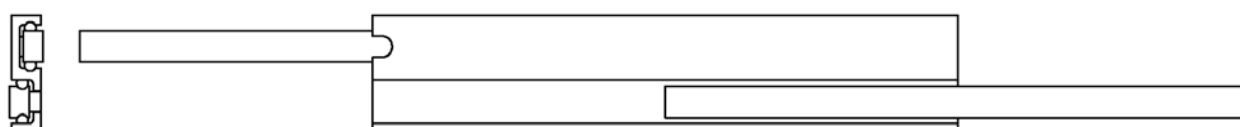

HEAVY DUTY EXTENSIONS

extension length 100% of the assembly length

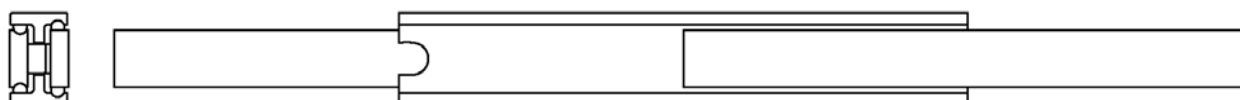

OVER EXTENSIONS

Extension length ca. 150 – 200% of the assembly length

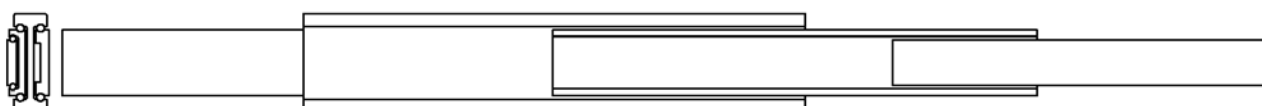

From these types numerous variations are derived in order to offer the ideal telescopic slide regards extension length, load magnitude and assembly. Further functions as forward / backward extension, special end stop dampers and lockings can supplementary be delivered.

Nadella aims to offer customized solutions with this product in a machine building quality. Telescopic slides are robust and need little maintenance for a long life. Economical solutions can be realized due to low supply costs and a simple assembly.

Nadella slides are linear guides with one or more carriages with re-circulation linear ball bearings running on a rail. Telescopic slides and guides are based on the same linear rails and can be combined with each other.

APPLICATIONS FOR NADELLA TELESCOPIC SLIDES

Nadella telescopic slides are used in many different areas, e.g. in the machine building, railcars, special vehicles for example in rescue vehicles, ship building or military vehicles, conveyor and storage techniques and many others. Telescopic slides are often used for battery boxes, handling and door systems, protection covers, switch cabinets, cashpoint (ATM) and other.

ASSEMBLY

An outer rail and one or more inner rails are the basic elements of the telescopic slides. As rolling element hardened balls are used which are kept in cages. With special chosen balls nearly zeroplay will be reached. A defined play for special enviromental conditions e.g. for high-temperature can be agreed. Standard end stops avoid an unintentional cutting of the different slide parts. All threads and fixing holes are easily accessible for assembly.

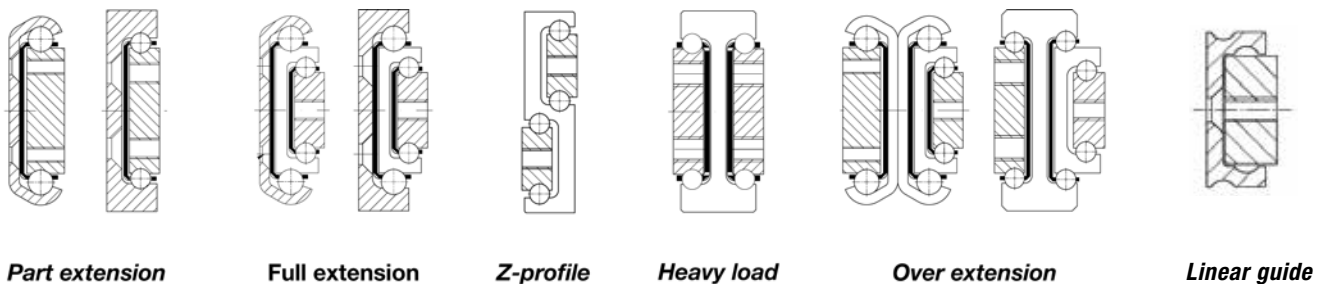

The standard mounting and extension lengths of each telescopic slide is shown in the dimension sheets. The standard lengths of many mounting sizes are divided into 50 and 100 mm steps. Special mounting lengths or special extensions can be provided upon customer's demand.

TECHNICAL INFORMATION

STANDARD LENGTHS' TOLERANCES

Installation length (mm)	≥ 150 < 420	≥ 420 < 1050	≥ 1050 < 2840
Tolerance (mm)	± 0,5	± 0,8	± 1,2

STEEL, STAINLESS STEEL (NX) AND ALUMINIUM (A)

Nadella telescopic rails are made of coil material or machined and drawn steel profiles. According to size and allowed load the most economic manufacturing process is used. All linear guides are surface coated and therefore effectively protected against corrosion. Alternatively, many telescopic slides can also be produced of stainless steel (NX variation) or aluminium (A).

STANDARD MATERIALS

The guides made of stainless steel (NX) have reduced basic load ratings (about 70%). The guides made of aluminium have a reduced weight and reach a basic load of about 30-40%.

	Guide rail	Cage	Ball
Standard	C45 (1.0503)	Steel coated	100Cr6 (1.3505)
Stainless steel (NX2/NX4)	NX2 load capacity -30% (1.4301)	Stainless steel	X46Cr13 (1.4034)
	NX4 load capacity -40% (1.4571)		
Aluminium (A)	3.3206 EV1 -70%	Stainless steel	X46Cr13 (1.4034)

CORROSION PROTECTION THROUGH SURFACE TREATMENT

All Nadella telescopic slides are surface treated and are effectively protected against corrosion for many applications. Depending on demand, application case and surrounding condition different surface treatments are possible or stainless steel version (NX) is available. The resistance of the surface treatments varies from 240 up to more than 700 hrs.

As standard NC1 we offer the telescopic slides with free zinc coating (Fe/Zn8/Top-Coat) with thick-layer passivation acc. to RoHS. The surface is silver shining with a slight blue gleam.

Shortcut	Coating	RoHS	Salt bath spraytest
NC1	Zinc-thick layer passivation	yes	about 240 hrs.
NC4	Zinc nickel plated with passivation	yes	over 700 hrs.

ADDITIONAL FUNCTIONS AND SPECIAL EQUIPMENTS

FORWARD AND BACKWARD EXTENSION (VR, VRM)

Many systems of the part and full extensions can be delivered as forward and backward extension.

The inner rails of full extensions in 3 parts can be controllably shifted through carriers (VRM). The advantage is a higher security because the unintentional moving of the middle rail of the backward extension can be prevented. The loads at the end of a telescopic slide can be better adopted with an optimum distribution of the rails.

END STOPS AND DAMPERS (EDG, FDOG)

End stops are standardized equipment for all telescopic slides. Furthermore special dampers can be provided for numerous extensions. There is the possibility to choose between simple cheap plastic or elastomer dampers – fixed directly at the end – or special spring dampers.

CATCHES (EHG, EHO, EOG) OR LOCKINGS (VO, VG, VOG)

Lockings are strong fixings via spring pieces which guarantee that a self movement of the extensions can effectively be prevented.

Catches are form fit fixing devices which fix the extensions with bolts or spring locks in their end positions. Without opening the spring lock none of the slides can move. This application is chosen for person and material safety reasons.

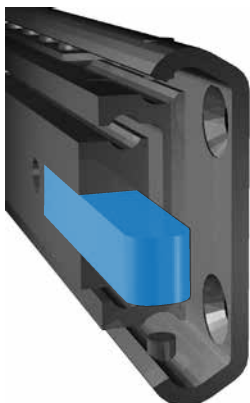
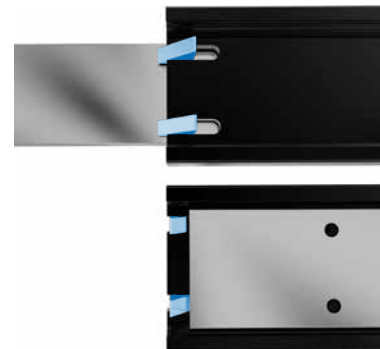

LOCKING



LOCKING PIN



VRM CARRIER

TECHNICAL INFORMATION

READY MADE COMPLETE SOLUTIONS

For special applications ready for installation complete solutions can be realized taking into account the economic lot size. These systems can be built out of telescopic rails with customized frame, end dampers, end stops or lockings and more.

CHOICE AND VARIATIONS OF TELESCOPIC SLIDES

Nadella telescopic slides are preferential made for static applications with lower dynamic. They are ideal because of their unhardened tracks and the robust and rigid body for high loads which must be moved from time to time, but they are also ideal for constant movements with lower dynamic.

GENERAL BASIC CONDITIONS:

- Pair wise operation
- Vertical installation position
- Center of gravity of load in the middle between telescopic slide pairs
- Center of gravity of load in the middle of the rail drawers
- Permissible loads can only be reached when using all standard fixing points

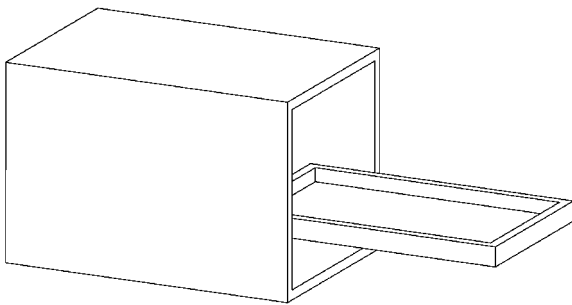

Standard application: Drawer extension telescopic rails vertical.

With horizontally installed telescopic rails up to 50 % of the allowed loads can be used depending on the type of rail. Besides the deflection will be significantly higher. Therefore a horizontally installation is recommended for a limited extend only when using small rails or extensions more than 600 mm.

If this is the case, please contact Nadella's technical service for additional information.



SPRING DEFLECTION

Spring deflection means the deflection of the full telescopic guide under maximum load. Telescopic rails which are correctly installed and with equally divided load between the extension pairs only have a very low deflection because of their rigid body. The standard telescopic rails have a spring deflection of approx. 1 % with the maximum use of the load, pair wise use and radial load (vertically mounted). For any application with tangential load or horizontal installations, please contact Nadella's technical service.

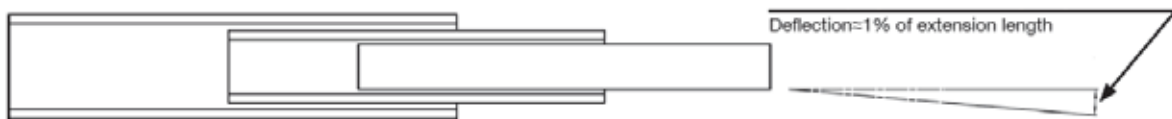

DYNAMIC AND LIFETIME

Telescopic rails are mainly aimed for static applications. The average speed with greased tracks are said to be up to 0,5 m/sec.

Higher speed or continuous operation or more than 10 strokes/min will negatively influence the lifetime. If higher dynamics are required you should use a bigger oversized guide rail and a reduced lubrication interval. You have also the possibility to use telescopic rails with nitrided surface. The standard operation temperature is between +10°C and +80°C, but depending on the application, the temperature range can be higher up to 300°C. In this case, adaptations must be made regards bearing air and eventually surface coating and special high temperature lubricants are necessary.

INSTALLATION OF TELESCOPIC RAILS

The telescopic rails with nearly zero play must be mounted parallel and angled for a perfect operation. All fixing holes and/or threads should be used for an optimum use of load.

Screws only with a strength grade of at least 8.8 should be used for assembly and to be fixed according to the screw producer's guidelines. Under certain circumstances the guide rails can be equipped with increased bearing air and can be mounted with a slight stroke.

TECHNICAL INFORMATION

MAINTENANCE AND LUBRICATION

All Nadella telescopic slides and guide rails are extremely maintenance free. Standard rails are delivered fully installed and greased. Rails made of stainless steel or aluminium will be delivered ungreased. Depending on the surrounding conditions they should be checked from time to time, dirt should be removed and “dry” rails should be regreased. This prevents friction, protects the assembly parts and provides a long life. The regreasing term is variable and should be calculated regards use conditions such as load, travel conditions, temperature, dirt etc..

The ball cages of the telescopic slides are not restraint-guided, consequently the cage can move. In this case the end positions have to be reset.