

GENERAL CATALOGUE

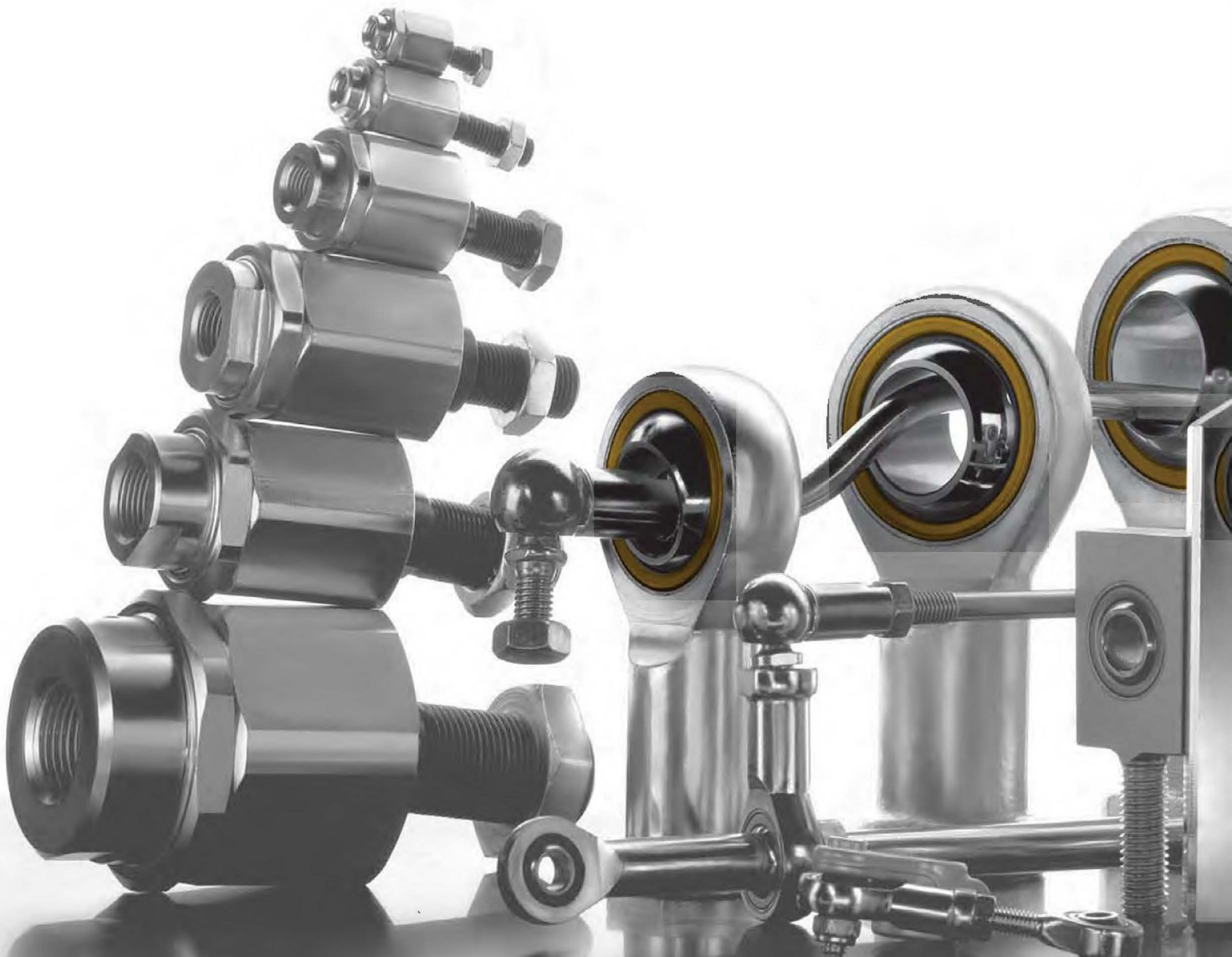

chiavette unificate
together in movement





chiavette unificate
together in movement

HEADQUARTERS

40069 Zola Predosa - Bologna - Italy - via Giacomo Brodolini, 6/8/10
Tel. +39 051 75.87.67 - Fax +39 051 75.47.80
Fax ufficio commerciale +39 051 616.51.26
mail: customer.service@chiavette.it www.chiavette.com

The total or partial reproduction of this technical catalogue is prohibited without prior permission. We cannot accept responsibility for errors or omissions. The reported dimensions and measures are not binding. We reserve the opportunity to change measures and dimensions at any time without notice.

9/2020



chiavette unificate

Chiavette Unificate sells its products worldwide and is located in Italy close to Bologna.

The Company started its activities in 1952: since then Chiavette always tried to follow the requirements and the developments of this sector and offers products that made and continue to make the history of the Company. From the craft stage during the first years to the industrial production based on high technology, we manufacture mechanical components, which are necessary for the motion of different systems and machineries. The company focuses on continuous improvements, consolidated management and production systems, details accuracy, the central role of people, quick innovation, and service efficiency; these values enable us to reach the customer's trust and transparency.

That's why we are **"together in movement"**. We're moving with you: we widened our range of products dedicated to our customers. Among our product range we have the Tescubal rod ends and spherical bearings (steel-bronze or steel-steel coupling), the Tesno rod ends and spherical bearings (steel-PTFE coupling), which are high resistance solutions, self lubricating and able to guarantee excellent performances even in case of heavy applications; the ball joints, axial joints and self aligning joints; the clevises and their accessories; the keys; the rod assemblies... Several solutions made of mild steel, stainless steel and aluminium. On the other hand special solutions and according to drawings can be easily supplied and managed, delivered directly to the customer's production line.

We always want to give you the right products according to your requirements and a dynamic service, which enables you to save time and money.



All together, these are the strengths of Chiavette Unificate

In our catalogue you can find our complete range of products, which are manufactured according to our Quality System certified by TÜV. You can deepen these informations visiting our web site www.chiavette.com, so that we can better know each other and work together, since the people of Chiavette Unificate S.p.A. will surely move with you.



A Company Certified According to UNI EN ISO 9001:2015

together in movement

	page
Electrolytic coatings	6
Standards comparison table	7
Self lubricating rod ends and spherical bearings.	
Introduction. Choice of the rod end and spherical bearing	9
Criteria of use	13
Tolerances	14
Joint clearance	15
Rod ends protections	16
Threaded pin for rod ends	17
TESCUBAL® steel on steel self-lubricating rod ends and spherical bearings	
 Product description	18
Rod ends TOP version	DIN ISO12240-4 Series K Series CF – CM 19
Rod ends OK version	DIN ISO12240-4 Series K Series CF OK – CM OK 22
Rod ends STAINLESS STEEL version	DIN ISO12240-4 Series K Series CFX – CMX 25
Spherical bearings TOP version	DIN ISO12240-1 Series K Series SB 28
Spherical bearings OK version	DIN ISO12240-1 Series K Series SB OK 29
TESNO® steel/PTFE self-lubricating rod ends and spherical bearings	
 Product description	30
Rod ends standard version	DIN ISO12240-4 Series K Series CFP – CMP 31
Rod ends STAINLESS STEEL version	DIN ISO12240-4 Series K Series CFPX – CMPX 34
Rod ends Ergal version	DIN ISO12240-4 Series K Series CFE – CME 37
Rod ends Ergal and STAINLESS STEEL version	DIN ISO12240-4 Series K Series CFEX – CMEX 39
Spherical bearings standard version	DIN ISO12240-1 Series K Series SPK 41
Spherical bearings STAINLESS STEEL version	DIN ISO12240-1 Series K Series SPKX 42
CLEVISES - Clevises and their accessories technical reading	
Product description	44
Technical data	44
Tolerances	45
Clevises	DIN 71752 Series G 46
Clevises	DIN 71752 ISO 8140 for pneumatic cylinders Series G/FG 48
Clevises	CNOMO 06-07-14 Series G/CN 49
Clevises	DIN 71752 STAINLESS STEEL version Series G INOX 50
Clevises DIN 71752 ISO 8140 STAINLESS STEEL version for pneumatic cylinders	Series G/FG INOX 51
Clevises - similar to	DIN 71752-Rotating shank Series GR 52
Clevises similar to	DIN 71752 with elongated hole Series GS 53
Clevises	DIN 71752 Aluminium version Series GA 54
Clevises DIN 71752 ISO 8140 Aluminium version for pneumatic cylinders	Series GA/FG 55
Mating piece for clevises	Series AG 56
ACCESSORIES FOR CLEVISES	
 Lockable pins for clevises	DIN 71752 Series G, G/FG and GA Series PM 57
Lockable pins for clevises	CNOMO Series G/CN Series PMC 58
Pins DIN 1434 for clevises	DIN 71752 Series G, G/FG Series PD 59
Washers DIN 433 for pins	DIN 1434 Series PDR 59
Split pins DIN 94 for pins	DIN 1434 Series PDC 59



Pins for clevises	DIN 71752 Series G, G/FG	Series PKS	60
Pins aluminium for clevises	DIN 71752 Series GA	Series PKSAL	61
Retainers for pins	Series PKS, PKSAL	Series SL	62
Retainers for pins	Series PKS, PKSAL	Series KL	63
Pins and circlips	DIN 471 for clevises CNOMO Series G/CN	Series PC - SE	64
Pins and circlips DIN 471 for clevises	DIN 71752 Series G/FG	Series PI - SE	65
Pins and circlips DIN 471 STAINLESS STEEL for clevises	DIN 71752 Series G/FG INOX	Series PI INOX - SE INOX	66
Hexagonal nuts UNI 5588 – 5589 (DIN 934 - DIN 936)			67

BALL JOINTS AND AXIAL JOINTS



Product description			68
Technical data			68
Ball joints	DIN 71802	CS - C form	70
Ball joints similar to	DIN 71802 long version	CSL - CL form	71
Ball joints similar to	DIN 71802 long version STAINLESS STEEL	CS - C form	72
Ball joints similar to	DIN 71802 long version STAINLESS STEEL	CSL form	73
Neoprene sealing cup for ball joints			73
Ball sockets	DIN 71805	A - B form	74
Ball sockets long version similar to	DIN 71805	AL - BL form	75
Ball sockets	DIN 71805 STAINLESS STEEL	A - B form	76
Ball sockets long version similar to	DIN 71805 STAINLESS STEEL	AL - BL form	77
Ball studs	DIN 71803	C - B form	78
Ball studs	DIN 71803 STAINLESS STEEL	C form	79
Safety Clips for	DIN 71805	S Series	80
Axial joints similar to	DIN 71752	AXA Series	81
Neoprene sealing cups for axial joints			81

SELF-ALIGNING JOINTS



Product description			83
Self-aligning joints		Series GB	82

FEATHER KEYS DIN 6885 – UNI 6604



Product description			83
Technical tables and tolerances			84
Feather keys	DIN 6885 – UNI 6604		86
Feather keys STAINLESS STEEL	DIN 6885 – UNI 6604		88

WOODRUFF KEYS DIN 6888 – UNI 6606



Technical tables and tolerances			89
Woodruff keys	DIN 6888 – UNI 6606 – ISO 3912		90
Woodruff keys	DIN 6888 – UNI 6606 – ISO 3912		91

SPECIAL PRODUCTS ACCORDING TO DRAWINGS

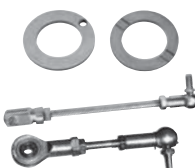

SHIMS			92
ROD ASSEMBLIES			93

ELECTROLYTIC COATINGS

This chapter specifies the characteristics required by electrolytic zinc coatings applied on components manufactured by Chiavette Unificate in carbon or tied steel, whose main purpose is to protect against corrosion, classify the types of coating, indicating the criteria of choice and prescribing the information to be put in the drawing.

The following tables are in accordance with the contents of ISO

COATING DESIGNATION CODE		ALTERNATIVE DESIGNATION	THICKNESS [μm]	CHROMATE TREATMENT	RESISTANCE IN SALT SPRAY	
					WHITE RUST [h]	RED RUST [h]
Fe/Zn	5c1A	A2J	5	A	6	24
Fe/Zn	5c1B	A2K		B	12	36
Fe/Zn	5c2C	A2L		C	48	72
		A2L CrIII				
Fe/Zn	5c2D	A2M		D	72	96
Fe/Zn	5Bk	A2S	Bk	12	-	
Fe/Zn	8c1A	A3J	8	A	6	48
Fe/Zn	8c1B	A3K		B	24	72
Fe/Zn	8c2C	A3L		C	72	120
		A3L CrIII				
Fe/Zn	8c2D	A3M		D	96	144
Fe/Zn	8Bk	A3S	Bk	24	72	
Fe/Zn	12c1A	A4J	12	A	6	72
Fe/Zn	12c1B	A4K		B	24	96
Fe/Zn	12c2C	A4L		C	72	144
		A4L CrIII				
Fe/Zn	12c2D	A4M		D	96	168
Fe/Zn	12Bk	A4S	Bk	24	96	

Description of the main designation (Fe/Zn 8c1A):

CLASS	DESIGNATION	TYPE	CHARACTERISTIC APPEARANCE	CORROSION PROTECTION
1	A	clear	Transparent, clear, sometimes with bluish tone	Low, for example against the formation of spots from handling or against high humidity in mildly corrosive conditions
	B	white	Transparent and slightly iridescent	
2	C	Iridescent	Iridescent yellow	High, including protection against certain organic vapors
	D	Opaque	Olive green with brown or bronze tones	
	Bk	Black	slightly iridescent Black	Different grades of protection against corrosion

Alternative designation example: A3J

A METAL/COATING ALLOY			3 COATING THICKNESS			J FINISH AND CHROMATE TREATMENT		
DESIGNATION	SYMBOL	ELEMENT	DESIGNATION.	COATING THICKNESS [μm]		DESIGNATION.	FINISH	CHARACTERISTIC APPEARANCE
A	Zn	Zinc		1 metal coating	2 metals coating	J	Bright	No color
			2	5	2+3	K		from bluish to bluish iridescent
			3	8	3+5	L		from yellowish reflex to iridescent yellow brown
			4	12	4+8	M		from opaque olive to olive brown
						S	Semi-bright	from brown-black to black

Designations 1A – 1B – 2C CrIII are Chrome VI free according to European Community Directives: 2002/95/EC concerning the restriction of certain hazardous substances in electrical and electronic devices (Directive RoHS); 2002/96/EC about waste of electrical and electronic devices (RAEE).

Other types of protection coatings

Iron-zinc alloy: Black alkaline zinc-iron alloy process

This minimum 8 micron thickness treatment guarantees a resistance to salt corrosion (ASTM B117) up to:

500 h to iron corrosion and up to 250 h to white oxide, for black color;

700 h to iron corrosion and up to 400 h to white oxide, for yellow color

Zinc-Nickel alloy: The process of Zn.Ni alloy (12-16% nickel content) guarantees the max. resistance to corrosion, applying few micron thickness, even in case of high temperatures (up to +200 C). Process of Zn.Ni alloy, black or grey color.

This process is complying with the EU Directives 2000/53/EC (RoHS), 2002/96 (WEEE) and guarantees a resistance as requested by the automotive sector specifications. To increase the resistance, it is possible to apply a sealer after the coating.

CHROMITING: Passivation for zinc electrolytic plating treatments and zinc alloys. This process is complying with the EU Directives 2000/53/EC (RoHS), 2002/96 (WEEE), slightly iridescent, with high resistance to corrosion.

Up to 400 hours in salt spray with 7um thickness, without white rust (ASTM B117) and without any need of a sealer. The thermal shock does not adversely affect corrosion resistance (test performed for 8 hours at 120).

Chromiting far exceeds the standard achieved by conventional hexavalent chrome yellow and green.

Chromiting is the process that had the largest number of awards in the automotive sector and which has the most use on an industrial scale.

To increase the resistance it is possible to use a sealer.

Sealing: The sealers can be applied to the passive layers after the processes of galvanizing and zinc alloys. They increase the resistance to corrosion.

NIPLOY PROCESS: The Niploy process is an exclusively chemical Nickel plating process with an high content of phosphorus, which allows to obtain a uniform deposit on treated surfaces, non-porous and highly resistant to corrosion and wear.

The deposit which arises from the Niploy treatment process ensures, thanks to the structure of the carry and the presence of phosphorus, a high resistance to corrosion, making it usable in application areas as pharmaceuticals and food, instead of stainless steel.

DACROMET®: DACROMET® is an inorganic coating based on zinc and aluminium flakes in a chromium binder. The anticorrosion performances are particularly high in case of thin treatments (from 5 to 10 m). DACROMET® is the reference technology concerning threaded fasteners for the automotive industry.

GEOMET®: Il GEOMET® is a water-based coating, composed of zinc and aluminium flakes in an inorganic binder. It is chromium free (neither Chrome VI nor Chrome III).

Standards comparison table

Standard material	Europe	Italy (IT)	Germany (DE)	France (FR)	Sweden (SE)	U.K.	Spain (ES)	U.S.A.
W. Nr.	EN	UNI	DIN	AFNOR	SS	B.S.	UNE	SAE/AISI
1.1186	C40	C40	Ck40	XC42H1	-	080M40	F1141	1040
1.1191	C45	C45	Ck45	XC 45	1672	080M46	F.1140	1045
1.0603	1 CS 67	C67	C67	XC 65	-	080A67	-	1070
1.0715	11SMn30	CF 9SMn28	9SMn28K	S250Pb	1912	230M07	F.2111	12L14
1.0718	11SMnPb30	CF 9SMnPb28	9SMnPb28K	S250Pb	1914	-	F.2112	12L13
1.0765	36SMnPb14	35SMnPb10	36SMnPb14	35MF6Pb	-	-	F.2132	-
1.3505	100Cr6	100Cr6	100Cr6	100Cr6	2258	2S135	F.1310	52100
1.7033	34Cr4	34Cr4	34Cr4	32C4	-	530A32	F.8221	5132
1.4301	X 5CrNi18-10	X 5CrNi18-10	X 5CrNi18-10	Z5CN18-09	2332	304S15	F.3504	304
1.4305	X8CrNiS 18-9	X10CrNiS18-09	X8CrNiS18-9	Z8CNF18-09	2346	303S22	F.3508	303
1.4401	X5CrNiMo17-12-2	X5CrNiMo1712	X5CrNiMo17-12-2	Z7CND17-12-02	2347	316S17	F.3534	316
1.4404	X2CrNiMo17-12-2	X 2CrNiMo1712	X2CrNiMo17132	Z3CND17-11-02	2348	316S14	F.3533	316L
1.4571	X6CrNiMoTi17-12-2	X6CrNiMoTi1712	X6CrNiMoTi17-12-2	Z6CNDT17-12	2350	320S18	F.3535	316Ti
1.4021	X20Cr13	X20Cr13	X20Cr13	Z20Cr13	2303	420S37	F.3402	420
1.6587	17NiCrMo6-4	18NiCrMo5	17NiCrMo6-4	18NCD6	2523	815M17	-	4317
1.6510	39NiCrMo3	39NiCrMo3	36CrNiMo4	40NCD3	-	-	F.1282	9840
1.7225	42CrMo4	42CrMo4	42CrMo4	42CD4	2244	708M40	F.1252	4140



1. INTRODUCTION

The rod ends and spherical bearings are mechanical junctions which, because of their internal geometry, are particularly suited for the transmission of static and dynamic forces, together with rotary, oscillatory and tipping movements.

They are standard products which are produced in accordance with ISO 12240-4 Series K and ISO 12240-1 Series K respectively.

The project takes into account the ever more stringent requirements of the market which calls for a reduced clearance, remaining constant with time, and completely maintenance free operation.

2. CHOICE OF ROD ENDS AND SPHERICAL BEARINGS

In order to make the appropriate choice of rod ends or spherical bearings it is important to know what their real application will be.

The type of load applied, static or dynamic, will be decisive for the correct dimensioning of the rod end or the spherical bearing.

Static Load

The static load means the maximum radial or axial load applied to the rod ends or spherical bearings in a static way, without oscillations or rotations, at room temperature, that does not cause permanent deformations or does not endanger its functionality.

The values of the maximum acceptable load were obtained by calculations and then checked on considerable samplings taken from our mass production.

Radial Static Load

The maximum acceptable radial static load for rod ends and spherical bearings is the one indicated on the dimensional table.

Axial Static Load

For the rod ends the maximum axial static load should not exceed the axial holding load of the joint on the head (table 1). Furthermore, it should be calculated basing on the length of engagement of the thread for the male type and on the male resistance connected to the female type.

For the spherical bearings the maximum acceptable axial static load is the one indicated in the dimensional tables.

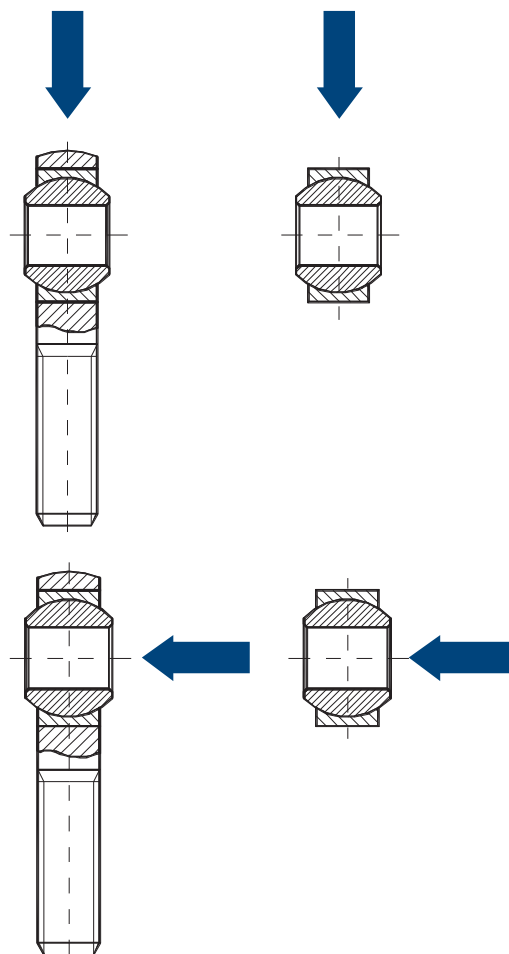

INNER RING HOLE DIAMETER	LOAD (daN)
5	100
6	120
8	170
10	200
12	270
14	400
16	550
18	580
20	600
22	700
25	800
30	1200
35	1400
40	1650
50	2000

Table 1

Axial holding load of the rod end

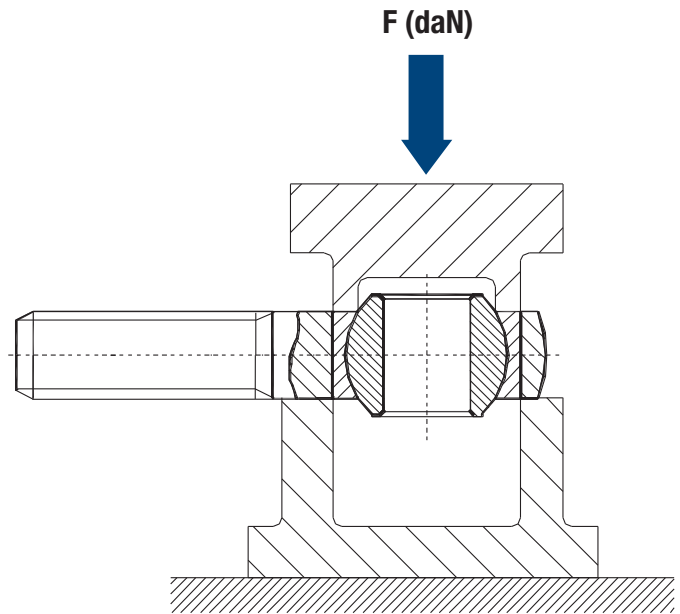

In case of dynamic load (load with relative movement between the inner and outer ring) it is necessary to carry out the following tests

a) Permissible radial load on the rod end

According to the type of load, it is indispensable to check the permissible stress.

Considering the same nominal load, dynamic loads produce greater stress on the rod end than constant loads; it is therefore necessary to introduce the coefficient K_f in the calculation of the permissible radial stress:

$$Fr_{amm.} = Co \times K_f$$

$Fr_{amm.}$ = maximum permissible load on the rod end (daN)

Co = permissible radial static load on the rod end (daN)

K_f = load coefficient (see the diagrams)

Fr = radial force applied (daN)

It is always important to verify the following condition: $Fr \leq Fr_{amm}$

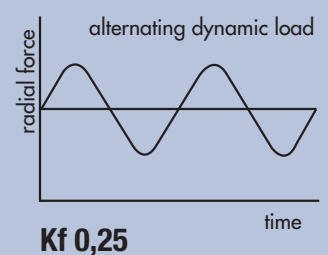
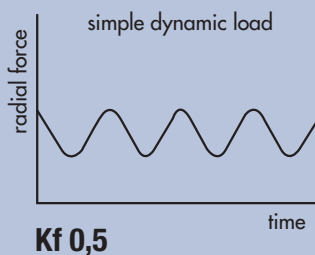
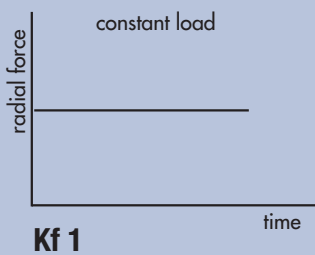

b) Permissible axial load on the rod end

Normally there are no dynamic axial loads, so the conditions to be observed are the ones given in the paragraph on static axial loads on page 9.

c) Equivalent load allowed

If both types of load, axial and radial, are applied to rod ends or spherical bearings, the equivalent load P will be calculated by the formula:

$$P = Fr \cdot X$$

- P** = equivalent load (daN)
- Fr** = radial load (daN)
- Fa** = axial load (daN)
- X** = axial load factor determined by the graph

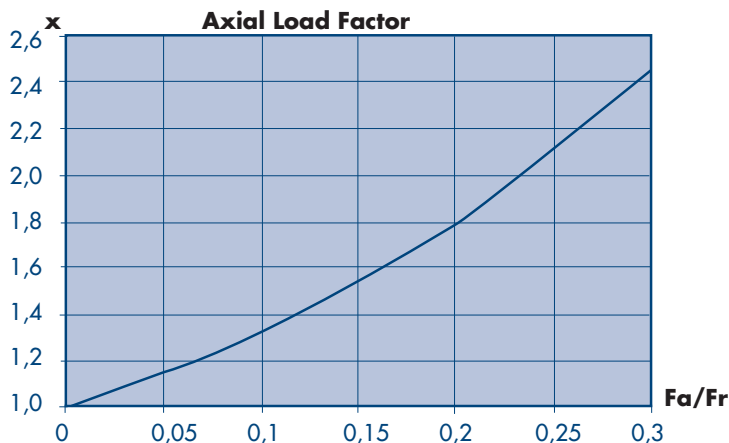

d) Specific pressure p allowed:

The specific pressure is the one detected between the inner ring and the surface on which it slides.

$$p = \frac{P}{dk \cdot C1}$$

- p** = specific pressure (daN/mm²)
- P** = equivalent load applied (daN)
- dk** = external diameter of the inner ring (mm)
- C1** = outer ring thickness (mm)

Check that the specific pressure allowed is included within the limits indicated on table 2

e) Sliding speed allowed:

The average sliding speed is the one detected between the inner ring and the surface on which it slides.

$$v = \frac{2 \cdot \pi \cdot \beta \cdot f \cdot dk}{180.000}$$

- v** = average sliding speed (m/min)
- β** = semi-angle of oscillation (°)
for complete rotation it is considered β = 90°
- f** = oscillations frequency or number of revolutions (min⁻¹)

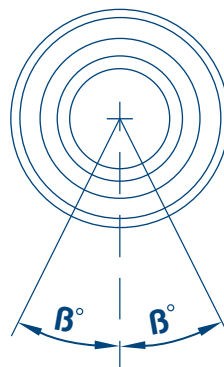

Check that the sliding speed allowed is included within the limits indicated on table 2

f) Permissible pv factor:

$$pv = p \cdot v$$

p = specific pressure (daN/mm²)

v = average sliding speed (m/min)

Check that the permissible sliding speed falls within the limits indicated in table 2.

Coupling	P max (daN/mm ²)	v max (m/min)	p.v max. (daN/mm ² •m/min)
Steel on sintered bronze	5	30	4
Steel on sintered steel	7	20	3
steel on PTFE	10	20	2,5

Table 2

It is important to point out that the above safety coefficients have been calculated on the basis of the standard use of the units. Where heavier use is made (with strong pulsating loads or compound stresses) or where the personal safety is at risk, it is essential to employ greater safety factors to reduce stress and where necessary practical tests corresponding to the real use should be carried out, in order to analyse the actual durability.

In case of these special applications we can take no responsibility for the product since we are unable to foresee the actual use to which it will be put.

g) Operating temperature

The operating temperatures of rod ends and spherical bearings are the following ones:

Coupling	Temperature °C	Max. temperature °C
Steel on sintered bronze	-30° a +120°	+150°
Steel on sintered steel	-30° a +120°	+150°
steel on PTFE	-40° a +200°	+250°

Remark: in case of high temperatures, the life of the rod end/spherical bearing will be reduced.

3. CRITERIA OF USE

Rod ends and spherical bearings are products, that do not need any kind of maintenance before or during operation. As precision components they maintain their performances unchanged only if the following criteria are observed:

- > keep them in their original packaging and stored them in a suitable place;
- > during assembly avoid that foreign bodies might get between the inner and the outer ring;
- > do not stress the outer ring during assembly/disassembly and do not put it in contact with any other parts outside the joint itself during working;
- > avoid shocks or damages during assembly.

Use of spherical bearings

It is essential that the assembly is made by following precise rules:

- > To make easier the assembly, the end of the shaft and the one of the housing should present a chamfer with an angle between 10° and 20°;
- > It is recommended to assemble the joint with a suitable bush (or tube) which sticks to the entire surface of the outer ring (fig.1); however, direct blows to the spherical bearings should be avoided.
- > In assembling the housing and the shaft, it is of primary importance to pay careful attention to the precision of the tolerances and to errors of form.

The chamfers of the shaft r1 and of the housing r2 should be inferior to those ones of the joint indicated on the dimensional tables (r1s and r2s respectively) (fig.1).

The choice of the coupling should not be made by chance, since a too much high interference may cancel the radial play between the outer and the inner ring, considerably increasing the friction and so compromising the spherical bearing's life. On the other hand, a loose coupling would cause a deformation of the outer ring, reducing its duration.

Therefore, the tolerances of the below mentioned table should be strictly followed:

LOAD TYPE	HOUSING	SHAFT
NORMAL	M7	m6
STRONG	N7	m6

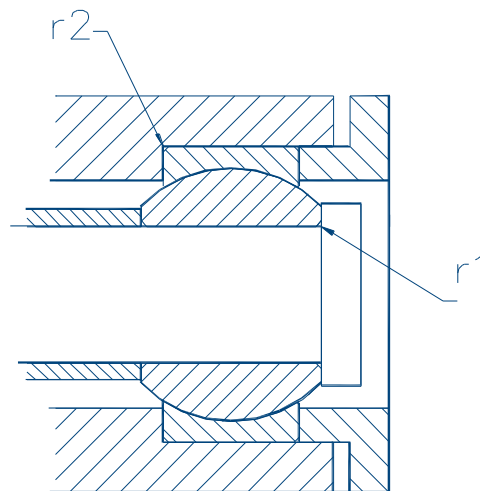

Picture 1

4. TOLERANCES

External Support

h, h1 height from the flat side of the shank to the centre of the hole in the inner ring

d3 screw thread in the shank

Outer ring of the rod end

D nominal external diameter

Δdmp deviation of the medium diameter of the hole from the nominal value

C nominal width

ΔCs variation of the nominal width C

Inner ring

d nominal diameter of the hole

B nominal width

Δdmp deviation of the medium diameter of the hole from the nominal value

ΔB variation in the nominal width B

Rod ends DIN ISO 12240-4 K Series

TYPE	d (mm)		Δdmp H7 (μm)		ΔBs (μm)		h, h ₁ (μm)	d ₃	
	over	up to	max	min	max	min		CF	CM
CF-CM CFX-CMX CFE-CME CFEX - CMEX CFP-CMP CFPX-CMPX	3	6	12	0	0	-120	±1200	6H	6g
	6	10	15	0	0	-120	±1200	6H	6g
	10	18	18	0	0	-120	±1200	6H	6g
	18	30	21	0	0	-120	±1700	6H	6g
	30	50	25	0	0	-120	±2100	6H	6g

Rod ends similar to DIN ISO 12240-4 K Series

TYPE	d (mm)		Δdmp H9 (μm)		ΔBs (μm)		h, h ₁ (μm)	d ₃	
	over	up to	max	min	Max	min		CF	CM
CF OK - CM OK	3	6	30	0	0	-120	±1200	6H	6g
	6	10	36	0	0	-120	±1200	6H	6g
	10	18	43	0	0	-120	±1200	6H	6g

Other tolerances according to DIN ISO 12240-1 K Series

Spherical bearings DIN ISO 12240-1 K Series

TYPE	Inner ring						Outer ring					
	d (mm)		Δdmp H7 (μm)		ΔBs (μm)		Δ (mm)		Δdmp (μm)		ΔCs (μm)	
	over	up to	max	min	max	min	over	up to	max	min	max	min
SB - SPK- SPKX	3	6	12	0	0	-120	5	18	0	-11	0	-240
	6	10	15	0	0	-120	18	30	0	-13	0	-240
	10	18	18	0	0	-120	30	50	0	-16	0	-240
	18	30	21	0	0	-120	50	80	0	-19	0	-240
	30	50	25	0	0	-120	80	120	0	-22	0	-240

Spherical bearings similar to DIN ISO 12240-1 K Series

TYPE	Inner ring						Outer ring					
	d (mm)		Δdmp H9 (μm)		ΔBs (μm)		Δ (mm)		Δdmp		ΔCs	
	over	up to	max	min	max	min	over	up to	max	min	max	min
SB OK	3	6	30	0	0	-120	5	18	0	-11	0	-240
	6	10	36	0	0	-120	18	30	0	-13	0	-240
	10	18	43	0	0	-120	30	50	0	-16	0	-240

Other tolerances according to DIN ISO 12240-1 K Series

5. CLEARANCE OF THE JOINT

The clearance of the joint indicates both the radial and axial movement of the inner ring as regards the outer ring. It is measured by applying a load of ± 10 daN (see picture)

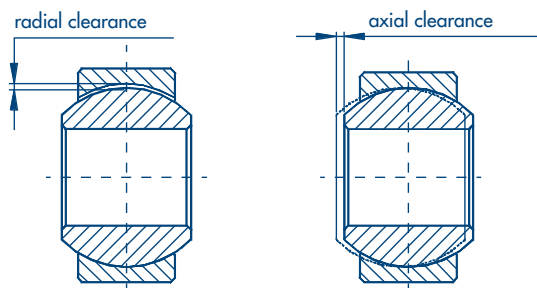

RADIAL CLEARANCE

Rod end

TYPE	Inner ring hole d		radial clearance (μm)	
	Over (mm)	Up to (mm)	min.	max.
TESCUBAL® CF - CM CF OK - CM OK CFX - CMX	3	6	5	50
	6	10	7	61
	10	18	8	75
	18	30	10	92
	30	50	13	112

TYPE	Inner ring hole d		radial clearance (μm)	
	Over (mm)	Up to (mm)	min.	max.
TESNO® CFP - CMP CFPX - CMPX CFE - CME CFEX - CMEX	3	6	5	45
	6	10	7	50
	10	18	8	55
	18	30	10	65
	30	50	13	80

Spherical bearing

TYPE	Inner ring hole d		radial clearance (μm)	
	Over (mm)	Up to (mm)	min.	max.
TESCUBAL® SB - SB OK	3	6	30	70
	6	10	40	80
	10	18	45	90
	18	30	50	100
	30	50	--	--

TYPE	Inner ring hole d		radial clearance (μm)	
	Over (mm)	Up to (mm)	min.	max.
TESNO® SPK - SPKX	3	6	30	70
	6	10	40	80
	10	18	45	90
	18	30	50	100
	30	50	--	--

NOTE WELL: the axial clearance is approx. 3-5 times the radial clearance

The radial clearance of the spherical bearing may vary according to the interference of the spherical bearing into its body. Therefore it is assembled with an oversize clearance so as to obtain the correct one.

Series
PTS

Series
DTS

SELF-LUBRICATING ROD ENDS
AND SPHERICAL BEARINGS

Series
ATS

chiavette unificate



6. PROTECTION OF ROD ENDS

PTS RUBBER COVERS (MADE OF NEOPRENE)

The protection allows the rod ends to be protected against dust, corrosive, chemical and atmospheric agents, etc...

Good resistance against oil, grease, chemical agents, salt spray.

It is not recommended for applications constantly in contact with oxidative agents and when the inner ring is subjected to complete revolutions or in case of high oscillating angle and anyway in case of high speeds.

Material: black Neoprene resistant from -30°C to $+120^{\circ}\text{C}$

DTS RINGS FOR RUBBER COVERS

Material: Nickel plated steel



For the mounting you can use a pair of pinchers suitable for the fixing of circlips (see picture)

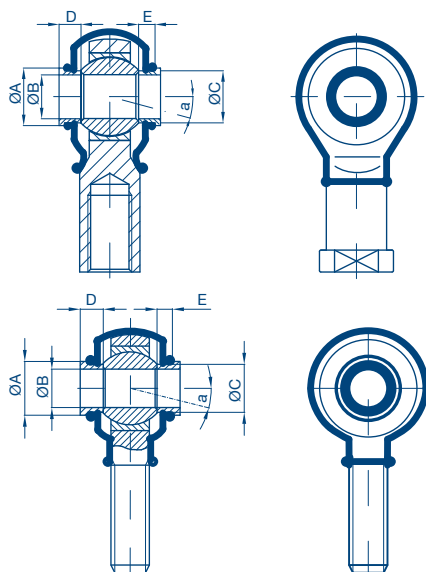

ROD END SIZE	COVERS MADE OF NEOPRENE	RINGS	ø A	ø B	ø C	D	E	α°
6	PTS 1	DTS 6	11	6	8,7	6	4	13
8		DTS 8	12	8	10,3	6	4	14
10	PTS 2	DTS 10	14	10	12,5	6	4	14
12		DTS 12	17	12	15	8	6	13
14	PTS 3	DTS 14	19	14	16,8	8	6	16
16		DTS 16	21	16	19	8	6	15
18	PTS 4	DTS 18	25	18	21	8	6	15
20		DTS 20	28	20	24	10	8	15
22		DTS 22	29	22	25	10	8	15
25		DTS 25	33	25	29	10	8	15

ATS PROTECTION RINGS

These side protections guarantee a longer life of the rod end, since they keep dust and dirt away from the inner and outer ring.

It is possible to use them even in case of complete revolutions of the inner ring.

Material: vulcanized rubber on stainless steel ring.

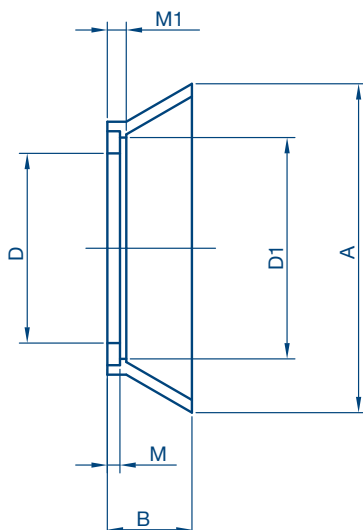

ROD END SIZE	RING TYPE	D	D1	B	M	M1	A
5	ATS 5	5,25	8,3	2,4	0,50	0,8	11,2
6	ATS 6	6,25	9,5	3,1	0,69	0,9	12,7
8	ATS 8	8,25	12,4	5,1	1,20	1,4	17,8
10	ATS 10	10,25	13,5	5,6	1,20	1,4	20,3
12	ATS 12	12,25	18,5	6,4	1,20	1,7	28,6
14	ATS 14	14,25	18,5	6,4	1,20	1,7	28,6
16	ATS 16	16,25	22,4	6,8	1,20	1,7	31,7
18	ATS 18	18,25	22,6	8,3	1,20	1,7	32,7
20	ATS 20	20,25	25,2	10,2	1,20	1,7	38,1
25	ATS 25	25,25	33,8	12,7	1,50	2,3	53,3
30	ATS 30	30,25	35,8	14,0	1,50	2,3	55,9

7. THREADED PIN FOR ROD ENDS DIN ISO 12240-4 Series K

Series

TB

Tipo: C...TB

CF
CFE
CFX
CFP
CFPX
CM
CME
CMX
CMP
CMPX

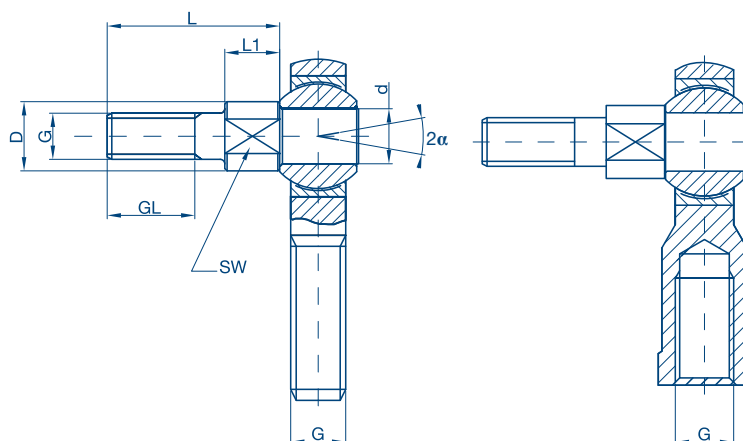

DESIGNATION	G	L	L1	GL	D	SW	α pivoting angle ≈	weight ≈ (kg)
5	M5 6g - 6H*	15	5	8	8	6	13	8
6	M6	18,5	5,5	10	9	8	13	10
8	M8	23,5	6,5	13	10,5	8	14	12
10	M10	28	7	17	13	12	13	25
12	M12	32,5	7,5	20	15	14	13	40
14	M14	37,5	8,5	22	17	14	15	65
16	M16	42,5	9,5	24	19	17	15	90
20	M20	57	12	35	24	22	14	200

* tolerance G: for external thread 6g -for threaded holes 6H

For left-hand thread add "L" (ex. CFL10M10 TB)
Exemple of designation: CF10 M10 TB

Technical reading from page 9 to page 15

MATERIAL

Rod ends:

See the description in the respective versions

Threaded pin:

automatic steel 11 SMnPb30 (1.0718 EN ISO 4042, Fe/Zn 8c 1B) galvanized surface by passivation free from hexavalent chromium. In alternative stainless steel XCrNi1810 (1.4301 - AISI 304)

SELF-LUBRICATING ROD ENDS

chiavette unificate

PRODUCT DESCRIPTION

The TESCUBAL® rod ends and spherical bearings are high resistance and precision products, which are made according to ISO 12240-4 K series and ISO 12240-1 K series.

They are maintenance free and employ a coupling of metal (inner ring) on sintered metal (outer ring) impregnated with a high potency lubricating fluid, which guarantees a constant lubrication.

The outer ring is cold formed on the inner ring, in order to guarantee a 100% surface contact, so that it can resist high loads and speeds, keeping the right lubrication during operation.

The main advantages of this product are:

- > Maintenance free operation, high load capacity and a reduced wear during operation, thanks to the metal/metal coupling and an appropriate and constant lubrication (our products don't need any maintenance even during the start)
- > Limited values of resistant couple which remain constant with time and an absence of stick-slip guaranteed by the lubricating fluid between the bush and the ball which ensures a low coefficient of friction
- > products are capable of functioning in the presence of or when immersed in oil
- > particularly suitable in case of oscillation movements, complete revolutions, high speeds...

Rod ends TOP version CF - CM series

Coupling: steel on bronze maintenance free

Support: from size 5 to size 12 are produced in automatic steel 11SMnPb30/37 (1.0718), successive sizes in forged, tempered steel C40 (1.1186)

Inner ring: tempered, ground and polished steel for bearings 100 Cr6 (1.3505)

Outer ring: sintered bronze impregnated with high-potency lubricating fluid, formed cold on the ball.

Rod ends OK version CF OK - CM OK series

Coupling: steel on steel maintenance free

Support: from size 5 to size 12 are produced in automatic, successive sizes in forged, tempered steel

Inner ring: tempered, ground and polished steel for bearings 34Cr4 (1.7033)

Outer ring: sintered steel impregnated with high-potency lubricating fluid, formed cold on the ball.

Rod ends STAINLESS STEEL version CFX - CMX series

Coupling: stainless steel on bronze maintenance free

Support: stainless steel X 5CrNi1810 (1.4301 – AISI 304)

Inner ring: tempered, ground and polished stainless steel X46Cr13 (1.4034 – AISI 420),

Outer ring: sintered bronze impregnated with high-potency lubricating fluid, formed cold on the ball.

Spherical bearings TOP version - SB series

Coupling: steel on steel maintenance free

Inner ring: tempered, ground and polished steel for bearings 100 Cr6 (1.3505)

Outer ring: sintered bronze impregnated with high-potency lubricating fluid, formed cold on the ball and grinded on the external diameter.

Spherical bearings OK version - SB OK series

Coupling: steel on steel maintenance free

Inner ring: tempered, ground and polished steel for bearings 34Cr4 (1.7033)

Outer ring: sintered steel impregnated with high-potency lubricating fluid, formed cold on the ball and grinded on the external diameter.

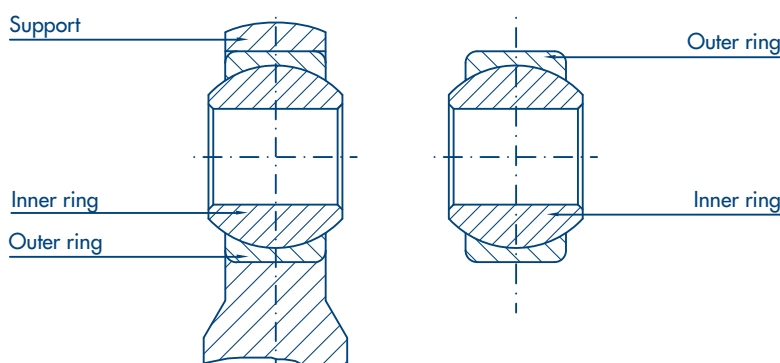

DIN ISO 12240-4 Series K Female thread

steel/bronze coupling, self-lubricating

Application: precision engineering, high speed

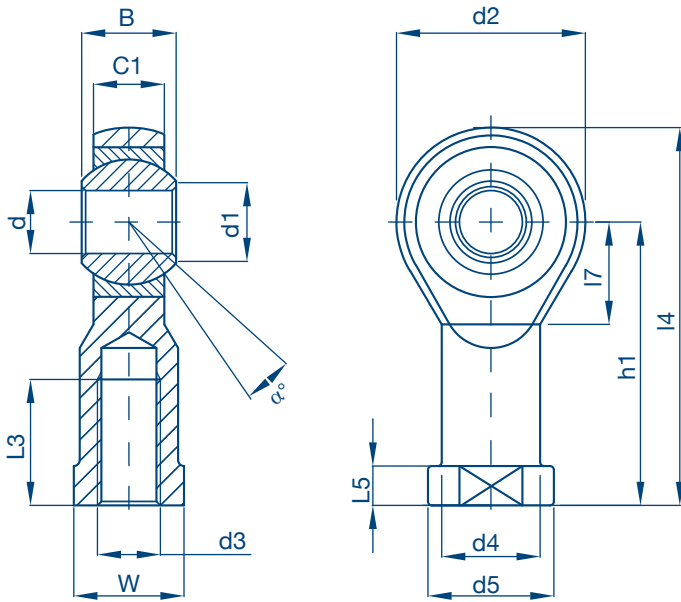

Series
CF

SELF-LUBRICATING ROD ENDS
TOP Version

Dimensions mm

DESIGNATION	d	d3	B	C1	d1	d2	d4	d5	dk	h1	L3	L4	L5	L7	W	static radial load Co. (daN)	α° pivoting angle \approx	weight \approx (kg)
	H7	6H																
CF5 M5	5	M5	8	6	7,7	18	9	11	11,11	27	10	36	4	10	9	600	13	0,019
CF6 M6	6	M6	9	6,75	8,9	20	10	13	12,7	30	12	40	5	11	11	700	13	0,026
CF8 M8	8	M8	12	9	10,4	24	12,5	16	15,87	36	16	48	5	13	14	1200	14	0,046
CF10 M10	10	M10	14	10,5	12,9	28	15	19	19,05	43	20	57	6,5	15	17	1400	13	0,074
CF12 M12	12	M12	16	12	15,4	32	17,5	22	22,22	50	22	66	6,5	17	19	1900	13	0,111
CF14 M14	14	M14	19	13,5	16,8	36	20	25	25,4	57	25	75	8	19	22	3600	15	0,156
CF16 M16	16	M16	21	15	19,3	42	22	27	28,57	64	28	85	8	23	22	4800	15	0,231
CF18 M18x1,5	18	M18x1,5	23	16,5	21,8	46	25	31	31,75	71	32	94	10	25	27	5100	15	0,295
CF20 M20	20	M20	25	18	24,3	50	27,5	34	34,92	77	33	102	10	27	30	5200	14	0,402
CF22 M22x1,5	22	M22x1,5	28	20	25,8	54	30	37	38,1	84	37	111	12	29	32	7500	15	0,490
CF25 M24x2	25	M24x2	31	22	29,5	60	33,5	42	42,85	94	42	124	12	32	36	8500	15	0,650
CF30 M30x2	30	M30x2	37	25	34,8	70	40	50	50,8	110	51	145	15	36	41	10800	17	1,126
CF35 M36x2	35	M36x2	43*	28	37,7*	80	46	58*	57,15	125	56	165	17,0*	41	50	12400	19*	1,635

*not included in DIN ISO 12240-4 norm

For left-hand thread add "L" (ex. CFL8 M8)
Technical reading from page 9 to page 15

MATERIAL

Support:

Up to size 12 automatic steel 11SMnPb30 (1.0718)
from size 14 hardened and tempered steel C40 (1.1186),
galvanized surface by passivation free from hexavalent
chromium (EN ISO 4042, Fe/Zn 8c 1B)

Inner ring:

tempered, ground and
polished steel for bearings
100 Cr6 (1.3505)

Outer ring:

sintered bronze
impregnated with high
efficiency lubricating fluid

DIN ISO 12240-4 Series K Male thread

steel/bronze coupling, self-lubricating

Application: precision engineering, high speed

Series
CM

SELF-LUBRICATING ROD ENDS
TOP Version

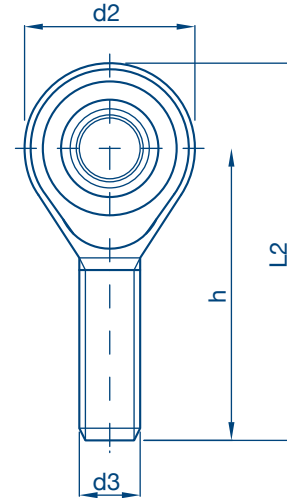
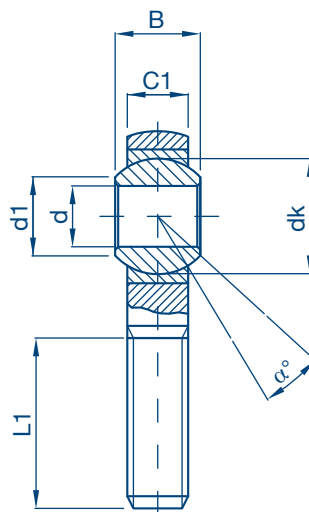

Dimensions mm

DESIGNATION	d H7	d3 6g	B	C1	d1	d2	dk	h	L1	L2	static radial load Co.(daN)	α° pivoting angle \approx	weight \approx (kg)
CM5 M5	5	M5	8	6	7,7	18	11,11	33	19	42	300	13	0,015
CM6 M6	6	M6	9	6,75	8,9	20	12,7	36	21	46	400	13	0,021
CM8 M8	8	M8	12	9	10,4	24	15,87	42	25	54	800	14	0,040
CM10 M10	10	M10	14	10,5	12,9	28	19,05	48	28	62	1300	13	0,064
CM10 M10x1,25	10	M10x1,25	14	10,5	12,9	28	19,05	48	28	62	1300	13	0,064
CM12 M12	12	M12	16	12	15,4	32	22,22	54	32	70	1700	13	0,097
CM12 M12x1,25	12	M12x1,25	16	12	15,4	32	22,22	54	32	70	1700	13	0,097
CM14 M14	14	M14	19	13,5	16,8	36	25,4	60	36	78	3600	15	0,130
CM16 M16	16	M16	21	15	19,3	42	28,57	66	37	87	4800	15	0,208
CM16 M16x1,5	16	M16x1,5	21	15	19,3	42	28,57	66	37	87	4800	15	0,208
CM18 M18x1,5	18	M18x1,5	23	16,5	21,8	46	31,75	72	41	95	5100	15	0,260
CM20 M20	20	M20	25	18	24,3	50	34,52	78	45	103	5200	14	0,367
CM20 M20x1,5	20	M20x1,5	25	18	24,3	50	34,92	78	45	103	5200	14	0,367
CM22 M22x1,5	22	M22x1,5	28	20	25,8	54	38,1	84	48	111	7500	15	0,435
CM25 M24x2	25	M24x2	31	22	29,5	60	42,85	94	55	124	8500	15	0,590
CM30 M30x2	30	M30x2	37	25	34,8	70	50,8	110	66	145	10800	15	1,060
CM35 M36x2	35	M36x2	43*	28	37,7*	80	57,15	140	85	180	12400	19*	1,640

For left-hand thread add "L" (ex. CML20 M20x1,5)

Technical reading from page 9 to page 15

MATERIAL

Support:

Up to size 12 automatic steel 11SMnPb30 (1.0718)
from size 14 hardened and tempered steel C40 (1.1186),
galvanized surface by passivation free from hexavalent
chromium (EN ISO 4042, Fe/Zn 8c 1B)

Inner ring:

tempered, ground and
polished steel for bearings
100 Cr6 (1.3505)

Outer ring:

sintered bronze
impregnated with high
efficiency lubricating fluid

*no standard dimension

DIN ISO 12240-4 Series K ISO 8139 (CETOP)
Female thread for pneumatic cylinders
steel/bronze coupling, self-lubricating
Application: precision engineering, high speed

Series
CF

SELF-LUBRICATING ROD ENDS
TOP Version

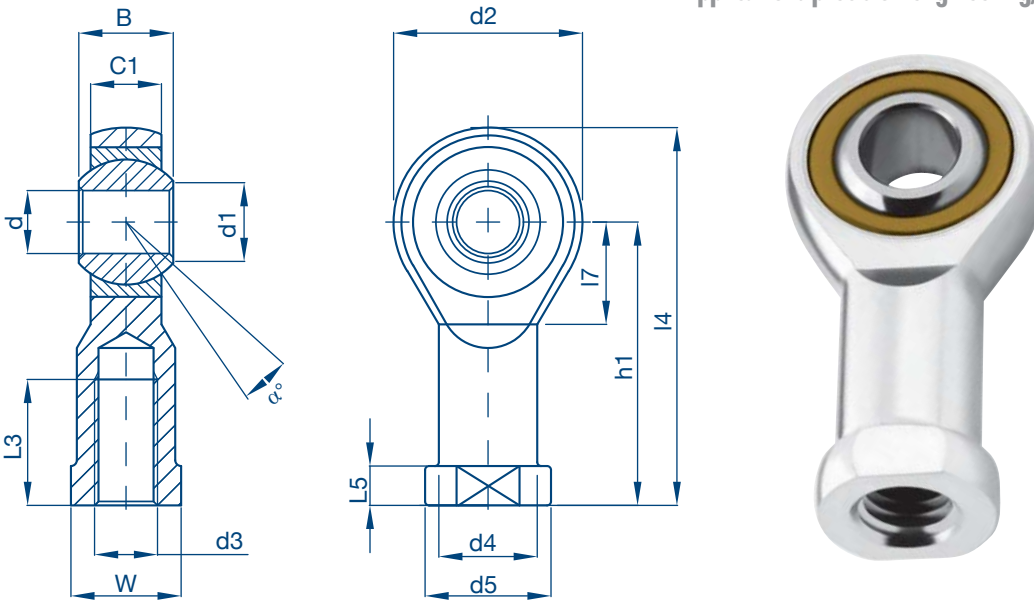

Dimensions mm

DESIGNATION	CYLINDER Ø	d H7	d3 6H	B	C1	d1	d2	d4	d5	dk	h1	L3	L4	L5	L7	W	static radial load Co.(daN)	α° pivoting angle ≈	weight ≈ (kg)
CF5 M4	8-10	5	M4	8	6	7,7	18	9	11	11,11	27	10	36	4	10	9	600	13	0,019
CF6 M6	12-16	6	M6	9	6,75	8,9	20	10	13	12,7	30	12	40	5	11	11	700	13	0,025
CF8 M8	20	8	M8	12	9	10,4	24	12,5	16	15,87	36	16	48	5	13	14	1200	14	0,046
CF10 M10x1,25	25-32	10	M10x1,25	14	10,5	12,9	28	15	19	19,05	43	20	57	6,5	15	17	1400	13	0,075
CF12 M12x1,25	40-50	12	M12x1,25	16	12	15,4	32	17,5	22	22,22	50	22	66	6,5	17	19	1900	13	0,112
CF16 M16x1,5	50-63	16	M16x1,5	21	15	19,3	42	22	27	28,57	64	28	85	8	23	22	4800	15	0,222
CF20 M20x1,5	80-100	20	M20x1,5	25	18	24,3	50	27,5	34	34,92	77	33	102	10	27	30	5200	14	0,406
CF25 M24x2	125	25	M24x2	31	22	29,5	60	33,5	42	42,85	94	42	124	12	32	36	8500	15	0,650
CF30 M27x2	125	30	M27x2	37	25	34,8	70	40	50	50,8	110	51	145	15	36	41	10800	17	1,119
CF35 M36x2	160-200	35	M36x2	43*	28	37,7*	80	46,0*	58*	57,15	125	56	165	17,0*	41	50	12400	19	1,595

*no standard dimension

For left-hand thread add "L" (ex. CFL6 M6)
Technical reading from page 9 to page 15

MATERIAL

Support:

Up to size 12 automatic steel 11SMnPb30 (1.0718)
from size 16 hardened and tempered steel C40 (1.1186),
galvanized surface by passivation free from hexavalent
chromium (EN ISO 4042, Fe/Zn 8c 1B)

Inner ring:

tempered, ground and
polished steel for bearings
100 Cr6 (1.3505)

Outer ring:

sintered bronze
impregnated with high
efficiency lubricating fluid

DIN ISO 12240-4 Series K Female thread

steel/steel coupling, self-lubricating

Application: general engineering

Series
CF OK

SELF-LUBRICATING ROD ENDS
OK Version

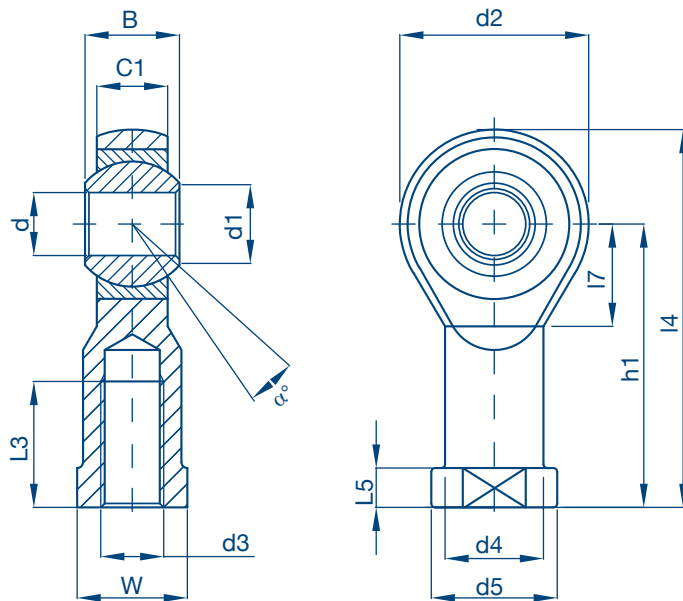

Dimensions mm

DESIGNATION	d H9*	d3 6H	B	C1	d1	d2	d4	d5	dk	h1	L3	L4	L5	L7	W	static radial load Co.(daN)	α° pivoting angle \approx	weight \approx (kg)
CF6 OK M6	6	M6	9	6,75	8,9	20	10	13	12,7	30	12	40	5	11	11	700	13	0,025
CF8 OK M8	8	M8	12	9	10,4	24	12,5	16	15,87	36	16	48	5	13	14	1200	14	0,046
CF10 OK M10	10	M10	14	10,5	12,9	28	15	19	19,05	43	20	57	6,5	15	17	1400	13	0,075
CF12 OK M12	12	M12	16	12	15,4	32	17,5	22	22,22	50	22	66	6,5	17	19	1900	13	0,112
CF16 OK M16	16	M16	21	15	19,3	42	22	27	28,57	64	28	85	8	23	22	4800	15	0,222

*no standard dimensions

For left-hand thread add "L" (ex. CFL16 OK M16)

Technical reading from page 9 to page 15

MATERIAL

Support:

Up to size 12 automatic steel 11SMnPb30 (1.0718)
from size 16 hardened and tempered steel C40 (1.1186),
galvanized surface by passivation free from hexavalent
chromium (EN ISO 4042, Fe/Zn 8c 1B)

Inner ring:

tempered, ground and
polished steel for bearings
34 Cr4 (1.7033)

Outer ring:

sintered steel
impregnated with high
efficiency lubricating fluid

DIN ISO 12240-4 Series K Male thread
steel/steel coupling, self-lubricating
Application: general engineering

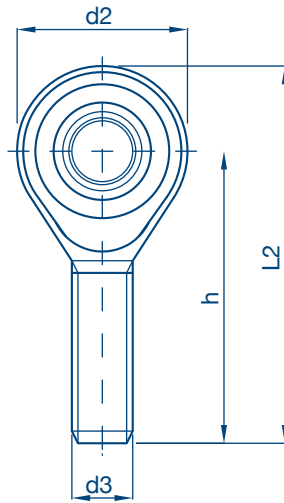
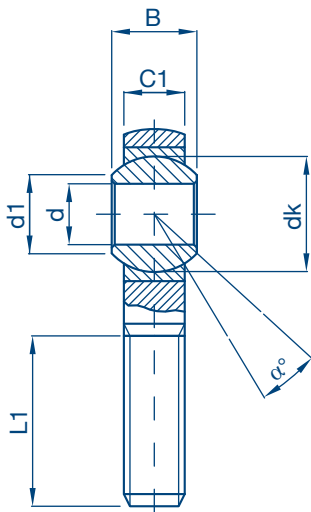

Series
CM OK

SELF-LUBRICATING ROD ENDS
OK Version

Dimensions mm

DESIGNATION	d H9*	d3 6g	B	C1	d1	d2	dk	h	L1	L2	static radial load Co.(daN)	α° pivoting angle \approx	weight \approx (kg)
CM6 OK M6	6	M6	9	6,75	8,9	20	12,70	36	21	46	400	13	0,021
CM8 OK M8	8	M8	12	9	10,4	24	15,87	42	25	54	800	14	0,040
CM10 OK M10	10	M10	14	10,5	12,9	28	19,05	48	28	62	1300	13	0,064
CM12 OK M12	12	M12	16	12	15,4	32	22,22	54	32	70	1700	13	0,097
CM16 OK M16	16	M16	21	15	19,3	42	28,57	66	37	87	4800	15	0,195

*no standard dimensions

For left-hand thread add "L" (ex. CML16 OK M16)
Technical reading from page 9 to page 15

MATERIAL

Support:

Up to size 12 automatic steel 11SMnPb30 (1.0718)
from size 14 hardened and tempered steel C40 (1.1186),
galvanized surface by passivation free from hexavalent
chromium (EN ISO 4042, Fe/Zn 8c 1B)

Inner ring:

tempered, ground and
polished steel for bearings
34 Cr4 (1.7033)

Outer ring:

sintered steel
impregnated with high
efficiency lubricating fluid

DIN ISO 12240-4 Series K ISO 8139 (CETOP) Female thread for pneumatic cylinders

steel/steel coupling, self-lubricating

Application: general engineering

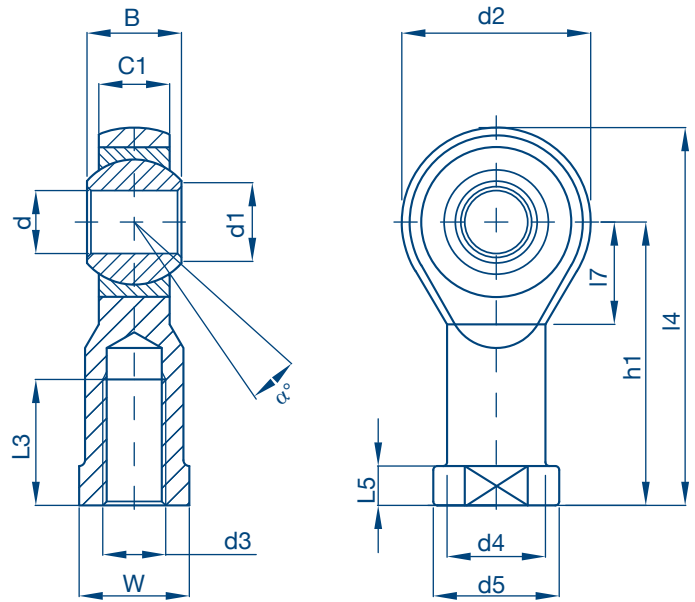

Dimensions mm

DESIGNATION	CYLINDER Ø	d H9*	d3 6H	B	C1	d1	d2	d4	d5	dk	h1	L3	L4	L5	L7	W	static radial load Co.(daN)	α° pivoting angle ≈	weight ≈ (kg)
CF6 OK M6	12-16	6	M6	9	6,75	8,9	20	10	13	12,7	30	12	40	5	11	11	700	13	0,025
CF8 OK M8	20	8	M8	12	9	10,4	24	12,5	16	15,87	36	16	48	5	13	14	1200	14	0,046
CF10 OK M10x1,25	25-32	10	M10x1,25	14	10,5	12,9	28	15	19	19,05	43	20	57	6,5	15	17	1400	13	0,075
CF12 OK M12x1,25	40-50	12	M12x1,25	16	12	15,4	32	17,5	22	22,22	50	22	66	6,5	17	19	1900	13	0,112
CF16 OK M16x1,5	50-63	16	M16x1,5	21	15	19,3	42	22	27	28,57	64	28	85	8	23	22	4800	15	0,222

For left-hand thread add "L" (ex. CFL6 OK M6)

Technical reading from page 9 to page 15

*no standard dimension

MATERIAL

Support:

Up to size 12 automatic steel 11SMnPb30 (1.0718)
from size 16 hardened and tempered steel C40 (1.1186),
galvanized surface by passivation free from hexavalent
chromium (EN ISO 4042, Fe/Zn 8c 1B)

Inner ring:

tempered, ground and
polished steel for bearings
34 Cr4 (1.7033)

Outer ring:

sintered steel
impregnated with high
efficiency lubricating fluid

Series
CF OK

SELF-LUBRICATING ROD ENDS
OK Version

chiavette unificate



DIN ISO 12240-4 Series K Female thread

steel/bronze coupling, self-lubricating

Application: precision engineering, suitable for oxidizing and corrosive environments

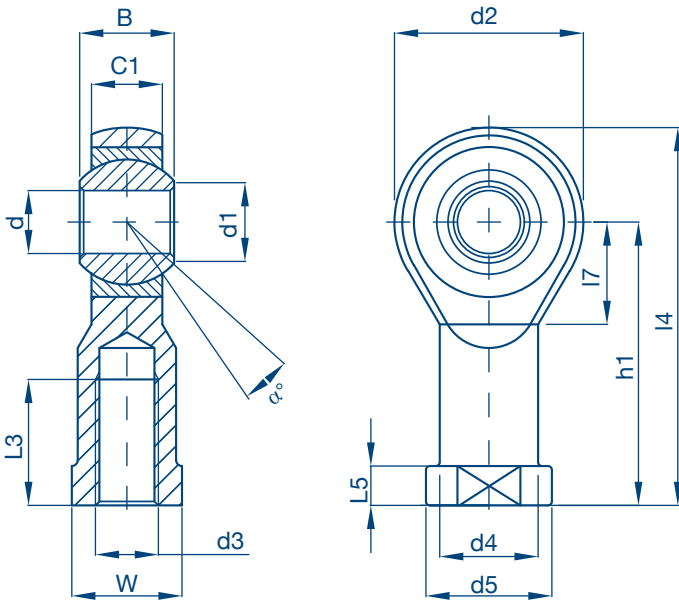

Series
CFX

SELF-LUBRICATING ROD ENDS
STAINLESS STEEL Version

Dimensions mm

DESIGNATION	d	d 3	B	C1	d1	d2	d4	d5	dk	h1	L3	L4	L5	L7	W	static radial load Co. (daN)	α° pivoting angle \approx	weight \approx (kg)
	H7	6H																
CFX5 M5	5	M5	8	6,00	7,7	18	9,0	11	11,11	27	10	36	4,0	10	9	600	13	0,019
CFX6 M6	6	M6	9	6,75	8,9	20	10,0	13	12,70	30	12	40	5,0	11	11	700	13	0,025
CFX8 M8	8	M8	12	9,00	10,4	24	12,5	16	15,87	36	16	48	5,0	13	14	1200	14	0,046
CFX10 M10	10	M10	14	10,50	12,9	28	15,0	19	19,05	43	20	57	6,5	15	17	1400	13	0,075
CFX12 M12	12	M12	16	12,00	15,4	32	17,5	22	22,22	50	22	66	6,5	17	19	1900	13	0,112
CFX14 M14	14	M14	19	13,50	16,8	36	20,0	25	25,40	57	25	75	8,0	19	22	3600	15	0,156
CFX16 M16	16	M16	21	15,00	19,3	42	22,0	27	28,57	64	28	85	8,0	23	22	4800	15	0,222
CFX20 M20	20	M20	25	18,00	24,3	50	27,5	34	34,92	77	33	102	10,0	27	30	5200	14	0,406

For left-hand thread add "L" (ex. CFXL16 M16)

Technical reading from page 9 to page 15

MATERIAL

Support:

stainless steel
X 5CrNi1810
(1.4301 - AISI 304)

Inner ring:

tempered, ground and
polished steel for bearings
X46Cr13
(1.4034 - AISI 420)

Outer ring:

sintered bronze
impregnated with high
efficiency lubricating fluid

DIN ISO 12240-4 Series K Male thread

steel/bronze coupling, self-lubricating

Application: precision engineering, suitable for oxidizing and corrosive environments

Series
CMX

SELF-LUBRICATING ROD ENDS
STAINLESS STEEL Version

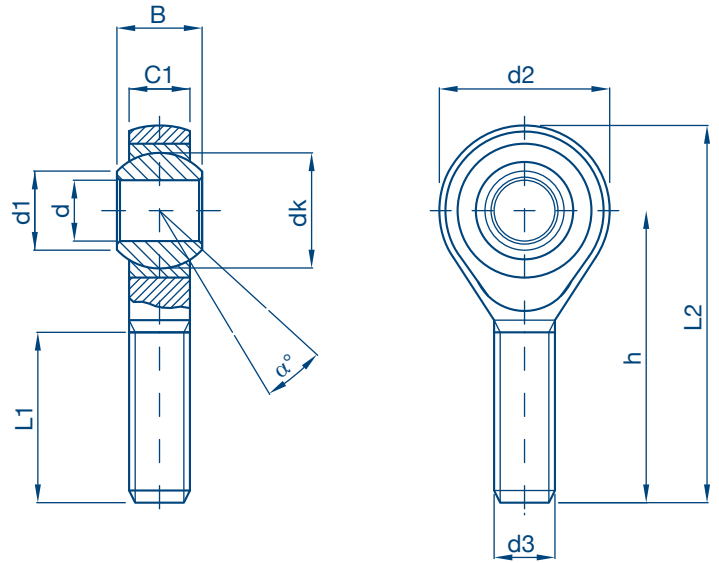

Dimensions mm

DESIGNATION	d H7	d3 6g	B	C1	d1	d2	dk	h	L1	L2	static radial load Co. (daN)	α° pivoting angle \approx	weight \approx (kg)
CMX5 M5	5	M5	8	6,00	7,7	18	11,11	33	19	42	300	13	0,015
CMX6 M6	6	M6	9	6,75	8,9	20	12,70	36	21	46	400	13	0,021
CMX8 M8	8	M8	12	9,00	10,4	24	15,87	42	25	54	800	14	0,040
CMX10 M10	10	M10	14	10,5	12,9	28	19,05	48	28	62	1300	13	0,064
CMX12 M12	12	M12	16	12,00	15,4	32	22,22	54	32	70	1700	13	0,097
CMX14 M14	14	M14	19	13,50	16,8	36	25,40	60	36	78	3600	15	0,130
CMX16 M16	16	M16	21	15,00	19,3	42	28,57	66	37	87	4800	15	0,208
CMX20 M20	20	M20	25	18,00	24,3	50	34,92	78	45	103	5200	14	0,367
CMX20 M20x1,5	20	M20x1,5	25	18,00	24,3	50	34,92	78	45	103	5200	14	0,367

For left-hand thread add "L" (ex. CMXL16 M16)

Technical reading from page 9 to page 15

MATERIAL

Support:

stainless steel
X 5CrNi1810
(1.4301 - AISI 304)

Inner ring:

stainless steel
X46Cr13
(1.4034 - AISI 420)

Outer ring:

sintered bronze
impregnated with high
efficiency lubricating fluid

DIN ISO 12240-4 Series K ISO 8139 (CETOP) Female thread for pneumatic cylinders

steel/bronze coupling, self-lubricating

Application: precision engineering, suitable for oxidizing and corrosive environments

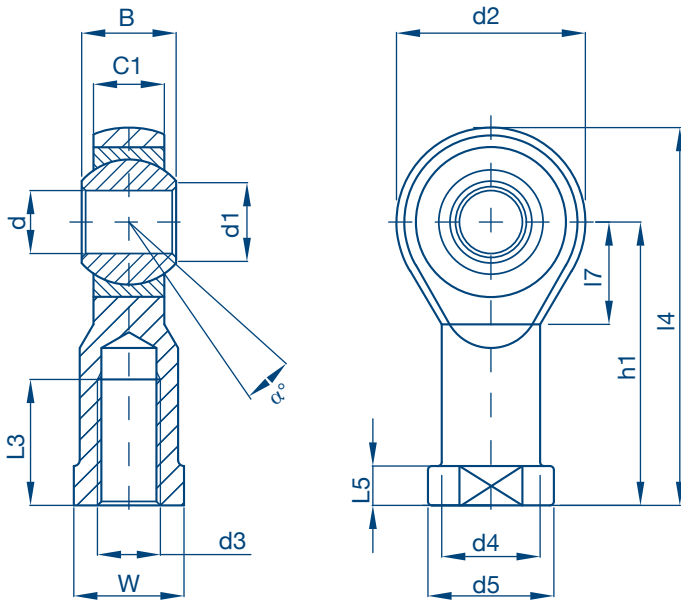

Series
CFX

SELF-LUBRICATING ROD ENDS
STAINLESS STEEL Version

Dimensions mm

DESIGNATION	CYLINDER Ø	d H7	d3 6H	B	C1	d1	d2	d4	d5	dk	h1	L3	L4	L5	L7	W	static radial load Co.(daN)	α° pivoting angle ≈	weight ≈ (kg)
CFX6 M 6	12-16	6	M6	9	6,75	8,9	20	10,0	13	12,70	30	12	40	5,0	11	11	700	13	0,025
CFX8 M 8	20	8	M8	12	9,00	10,4	24	12,5	16	15,87	36	16	48	5,0	13	14	1200	14	0,0465
CFX10 M 10x1,25	25-32	10	M10x1,25	14	10,50	12,9	28	15,0	19	19,05	43	20	57	6,5	15	17	1400	13	0,075
CFX12 M 12x1,25	40-50	12	M12x1,25	16	12,00	15,4	32	17,5	22	22,22	50	22	66	6,5	17	19	1900	13	0,112
CFX16 M16x1,5	50-63	16	M16x1,5	21	15,00	19,3	42	22,0	27	28,57	64	28	85	8,0	23	22	4800	15	0,222
CFX20 M20x1,5	80-100	20	M20x1,5	25	18,00	24,3	50	27,5	34	34,92	77	33	102	10,0	27	30	5200	14	0,406

For left-hand thread add "L" (ex. CFXL10 M10x1,25)
Technical reading from page 9 to page 15

MATERIAL

Support:

stainless steel
X 5CrNi1810
(1.4301 - AISI 304)

Inner ring:

tempered, ground and
polished steel for bearings
X46Cr13
(1.4034 - AISI 420)

Outer ring:

sintered bronze
impregnated with high
efficiency lubricating fluid

DIN ISO 12240-1 Series K
steel/steel coupling, self-lubricating
Application: precision engineering

Series
SB

SELF-LUBRICATING SPHERICAL BEARINGS
TOP Version

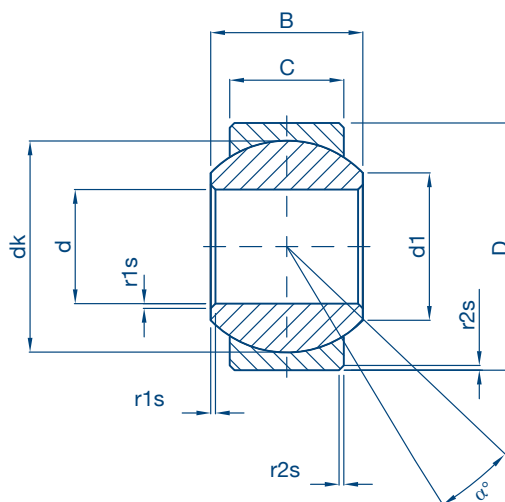

Dimensions mm

DESIGNATION	d H7	B	C	D h6	d1	dk	r1s min.	r2s min.	static radial load Co.(daN)	static axial load Co.(daN)	α° pivoting angle \approx	weight \approx (kg)
SB6	6	9	6,75	16	8,9	12,70	0,3	0,3	1700	220	13	0,009
SB8	8	12	9,00	19	10,4	15,87	0,3	0,3	2800	370	14	0,016
SB10	10	14	10,50	22	12,9	19,05	0,3	0,3	4000	520	13	0,025
SB12	12	16	12,00	26	15,4	22,22	0,3	0,3	5300	700	13	0,040
SB16	16	21	15,00	32	19,3	28,57	0,3	0,3	8500	1100	15	0,100
SB20	20	25	18,00	40	24,3	34,92	0,3	0,6	12500	1600	14	0,150
SB30	30	37	25,00	55	34,8	50,80	0,3	0,6	25400	3300	17	0,380
SB35	35	43	28,00*	62*	37,7*	57,15	0,6	1,0	32000	4150	19	0,490

Technical reading from page 9 to page 15

*no standard dimension

MATERIAL

Inner ring:

tempered, ground and polished steel for bearings
100 Cr6 (1.3505)

Outer ring:

sintered steel impregnated with high efficiency lubricating fluid

DIN ISO 12240-1 Series K
steel/steel coupling, self-lubricating
Application: general engineering

Series
SB OK

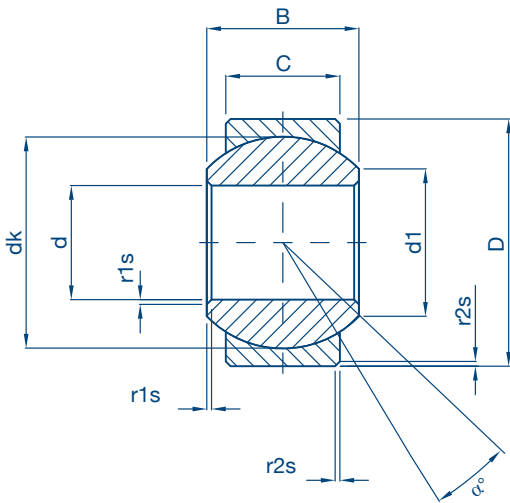

Dimensions mm

DESIGNATION	d H9*	B	C	D h6	d1	dk	r1s min.	r2s min.	static radial load Co.(daN)	static axial load Co.(daN)	α° pivoting angle \approx	weight \approx (kg)
SB6-OK	6	9	6,75	16	8,9	12,70	0,3	0,3	1700	220	13	0,009
SB8-OK	8	12	9,00	19	10,4	15,87	0,3	0,3	2800	370	14	0,016
SB10-OK	10	14	10,50	22	12,9	19,05	0,3	0,3	4000	520	13	0,025
SB12-OK	12	16	12,00	26	15,4	22,22	0,3	0,3	5300	700	13	0,040
SB16-OK	16	21	15,00	32	19,3	28,57	0,3	0,3	8500	1100	15	0,100

*no standard dimensions

Technical reading from page 9 to page 15

MATERIAL

Inner ring:

tempered, ground and polished steel for bearings 34Cr4 (1.7033)

Outer ring:

sintered steel impregnated with high efficiency lubricating fluid

SELF-LUBRICATING SPHERICAL BEARINGS
OK Version

PRODUCT DESCRIPTION

The **TESNO®** rod ends and spherical bearings are high quality products and are made according to ISO 12240-4 K series and ISO 12240-1 K series respectively.

They are maintenance free and employ coupling of metal (inner ring) on PTFE (bonded to the inner surface of the outer ring), which guarantees the lubrication during the operation.

The bronze outer ring containing the PTFE liner is cold formed on the inner ring.

The main advantages of this product are:

- › High loads and maintenance free
- › Suitable in case of small pivoting angles, dynamic load peaks and movements with a low friction coefficient

Rod ends STANDARD version CFP - CMP series

Coupling: steel on PTFE liner, maintenance free

Support: from size 5 to size 12 are produced in automatic steel 11SMnPb30/37 (1.0718), successive sizes in forged, tempered steel C40 (1.1186). Zinc plated surface (EN ISO 4042 Fe/Zn 8c 1B)

Inner ring: tempered, ground and polished steel for bearings 100 Cr6 (1.3505)

Outer ring: brass with PTFE bonded on the inner surface.

Rod ends STAINLESS STEEL version CFPX - CMPX series

Coupling: steel on PTFE liner, maintenance free

Support: stainless steel X 5CrNi1810 (1.4301 – AISI 304)

Inner ring: tempered, ground and polished stainless steel X46Cr13 (1.4034 – AISI 420)

Outer ring: stainless steel X 5CrNi1810 (1.4301 – AISI 304) with PTFE bonded on the inner surface.

Rod ends ERGAL version CFE - CME series

Coupling: steel on PTFE liner, maintenance free

Support: ERGAL (7075 alloy state T6) with anodized surface

Inner ring: tempered, ground and polished steel for bearings 100 Cr6 (1.3505)

Outer ring: carbon steel C45 (1.1191) with PTFE bonded on the inner surface.

Rod ends ERGAL and STAINLESS STEEL version CFE - CMEX series

Coupling: stainless steel on PTFE liner, maintenance free

Support: ERGAL (7075 alloy state T6) with anodized surface

Inner ring: tempered, ground and polished stainless steel X46Cr13 (1.4034 – AISI 420)

Outer ring: stainless steel X 5CrNi1810 (1.4301 – AISI 304) with PTFE bonded on the inner surface.

Spherical bearings STANDARD version SPK series

Coupling: steel on PTFE liner maintenance free

Inner ring: tempered, ground and polished steel for bearings 100 Cr6 (1.3505)

Outer ring: carbon steel C45 (1.1191) with PTFE bonded on the inner surface.

Spherical bearings STAINLESS STEEL version SPKX series

Coupling: stainless steel on PTFE liner maintenance free

Inner ring: tempered, ground and polished stainless steel X46Cr13 (1.4034 – AISI 420)

Outer ring: stainless steel X 5CrNi1810 (1.4301 – AISI 304) with PTFE bonded on the inner surface.

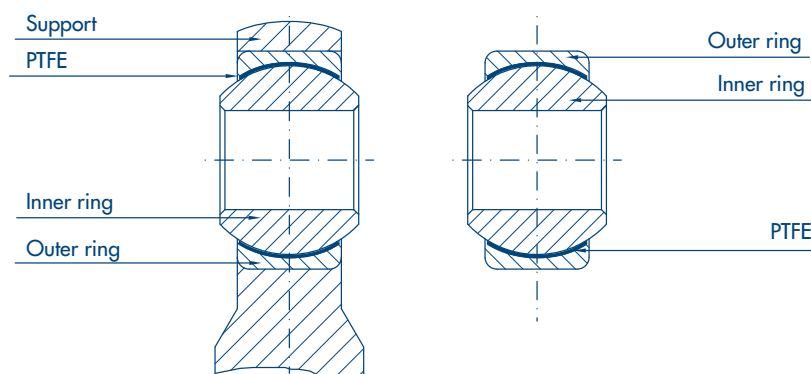

DIN ISO 12240-4 Series K Female thread

Coupling: steel/PTFE

Application: precision engineering

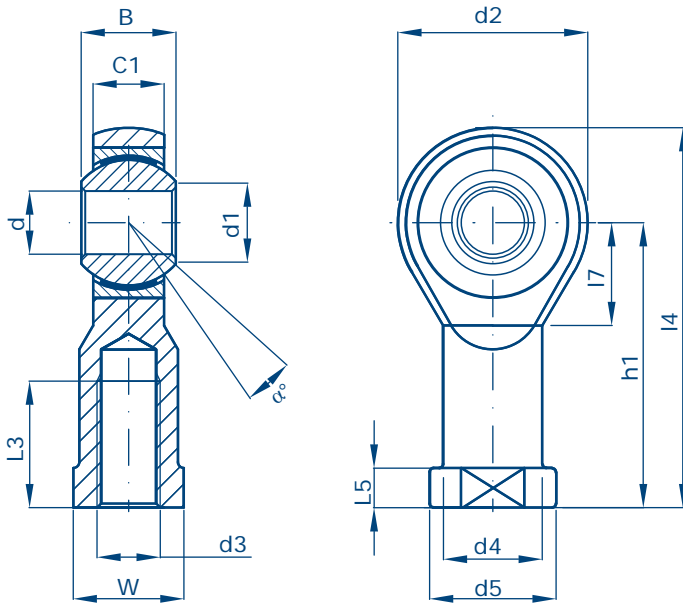

Series
CFP

**SELF-LUBRICATING ROD ENDS
STANDARD Version**

Dimensions mm

DESIGNATION	d	d3	B	C1	d1	d2	d4	d5	dk	h1	L3	L4	L5	L7	W	static radial load Co. (daN)	α° pivoting angle \approx	weight \approx (kg)
	H7	6H																
CFP5 M5	5	M5	8	6	7,7	18	9	11	11,11	27	10	36	4	10	9	600	13	0,019
CFP6 M6	6	M6	9	6,75	8,9	20	10	13	12,7	30	12	40	5	11	11	700	13	0,026
CFP8 M8	8	M8	12	9	10,4	24	12,5	16	15,87	36	16	48		13	14	1200	14	0,046
CFP10 M10	10	M10	14	10,5	12,9	28	15	19	19,05	43	20	57	6,5	15	17	1400	13	0,074
CFP12 M12	12	M12	16	12	15,4	32	17,5	22	22,22	50	22	66	6,5	17	19	1900	13	0,111
CFP14 M14	14	M14	19	13,5	16,8	36	20	25	25,4	57	25	75	8	19	22	3600	15	0,156
CFP16 M16	16	M16	21	15	19,3	42	22	27	28,57	64	28	85	8	23	22	4800	15	0,231
CFP18 M18x1,5	18	M18x1,5	23	16,5	21,8	46	25	31	31,75	71	32	94	10	25	27	5100	15	0,295
CFP20 M20	20	M20	25	18	24,3	50	27,5	34	34,92	77	33	102	10	27	30	5200	14	0,402
CFP22 M22x1,5	22	M22x1,5	28	20	25,8	54	30	37	38,1	84	37	111	12	29	32	7500	15	0,49
CFP23 M24x2	25	M24x2	31	22	29,5	60	33,5	42	42,85	94	42	124	12	32	36	8500	15	0,65
CFP30 M27x2	30	M27x2	37	25	34,8	70	40	50	50,8	110	51	145	15	36	41	10800	17	1,126
CFP30 M30x2	30	M30x2	37	25	34,8	70	40	50	50,8	110	51	145	15	36	41	10800	17	1,119
CFP35 M36x2	35	M36x2	43*	28	37,7*	80	46	58*	57,15	125	56	165	17,0*	41	50	12400	19*	1,635
CFP40 M42x2	40	M42x2	49*	33	45,1*	91	53	65*	66,6	142	60	187	19*	45	55	26000	16*	2,400
CFP50 M48x2	50	M48x2	60*	45	56,6*	117	65	75*	82,5	162	65	218	23*	58	65	30800	14*	5,000

*no standard dimension

For left-hand thread add "L" (ex. CFPL8 M8)
 Technical reading from page 9 to page 15

MATERIAL

Support:

Up to size 12 automatic steel 11SMnPb30 (1.0718)
 from size 14 hardened and tempered steel C40 (1.1186),
 galvanized surface by passivation free from hexavalent
 chromium (EN ISO 4042, Fe/Zn 8c 1B)

Inner ring:

tempered, ground and
 polished steel for bearings
 100 Cr6 (1.3505)

Outer ring:

brass and PTFE
 bonded on the inner
 surface

DIN ISO 12240-4 Series K Male thread

Coupling: steel/PTFE

Application: precision engineering

Series
CMP

SELF-LUBRICATING ROD ENDS
STANDARD Version

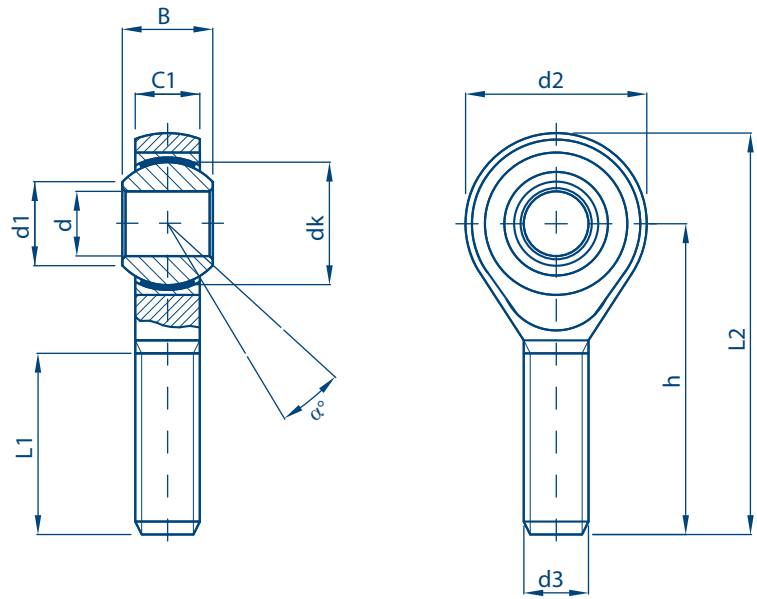

Dimensions mm

DESIGNATION	d	d3	B	C1	d1	d2	dk	h	L1	L2	static radial load Co. (daN)	α° pivoting angle \approx	weight \approx (kg)
	H7	6g											
CMP5 M5	5	M5	8	6	7,7	18	11,11	33	19	42	300	13	0,015
CMP6 M6	6	M6	9	6,75	8,9	20	12,7	36	21	46	400	13	0,021
CMP8 M8	8	M8	12	9	10,4	24	15,87	42	25	54	800	14	0,040
CMP10 M10	10	M10	14	10,5	12,9	28	19,05	48	28	62	1300	13	0,064
CMP12 M12	12	M12	16	12	15,4	32	22,22	54	32	70	1700	13	0,097
CMP14 M14	14	M14	19	13,5	16,8	36	25,4	60	36	78	3600	15	0,13
CMP16 M16	16	M16	21	15	19,3	42	28,57	66	37	87	4800	15	0,208
CMP16 M16x1,5	16	M16x1,5	21	15	19,3	42	28,57	66	37	87	4800	15	0,208
CMP18 M18x1,5	18	M18x1,5	23	16,5	21,8	46	31,75	72	41	95	5100	15	0,260
CMP20 M20	20	M20	25	19	24,3	50	34,52	78	45	103	5200	14	0,367
CMP20 M20x1,5	20	M20x1,5	25	18	24,3	50	34,92	78	45	103	5200	14	0,367
CMP22 M22x1,5	22	M22x1,5	28	20	25,8	54	38,1	84	48	111	7500	15	0,435
CMP25 M24x2	25	M24x2	31	22	29,5	60	42,85	94	55	124	8500	15	0,590
CMP30 M30x2	30	M30x2	37	25	34,8	70	50,8	110	66	145	10800	15	1,060
CMP35 M36x2	35	M36x2	43*	28	37,7	80	57,15	140	85	180	12400	19*	1,640
CMP40 M42x2	40	M42x2	49*	33	45,1	91	66,60	150	90	195	26000	16*	2,300
CMP50 M48x2	50	M48x2	60*	45	56,6	117	82,50	185	105	243	30800	14*	4,800

For left-hand thread add "L" (ex. CMPL8 M8)

Technical reading from page 9 to page 15

MATERIAL

Support:

Up to size 12 automatic steel 11SMnPb30 (1.0718)
from size 14 hardened and tempered steel C40 (1.1186),
galvanized surface by passivation free from hexavalent
chromium (EN ISO 4042, Fe/Zn 8c 1B)

Inner ring:

tempered, ground and
polished steel for bearings
100 Cr6 (1.3505)

Outer ring:

brass and PTFE
bonded on the inner
surface

*no standard dimension

DIN ISO 12240-4 Series K ISO 8139 (CETOP) Female thread for pneumatic cylinders

Coupling: steel/PTFE

Application: precision engineering

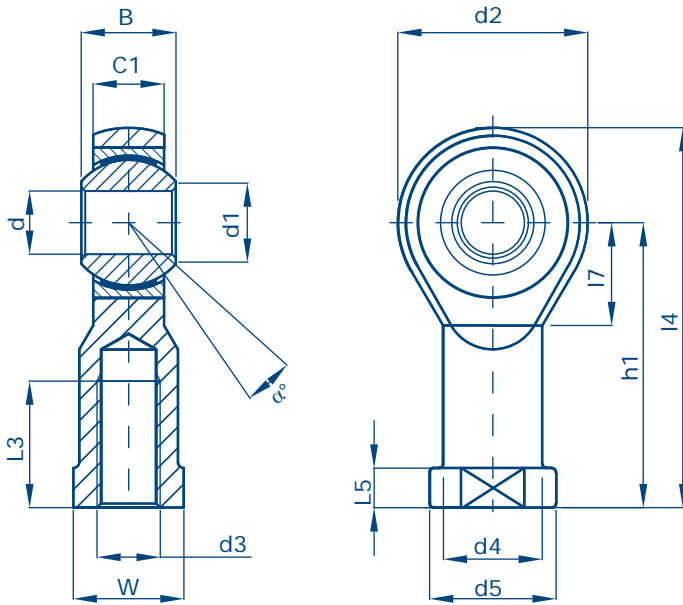

Series
CFP

**SELF-LUBRICATING ROD ENDS
 STANDARD Version**

Dimensions mm

DESIGNATION	CYLINDER Ø	d	d3	B	C1	d1	d2	d4	d5	dk	h1	L3	L4	L5	L7	W	static radial load Co.(daN)	α° pivoting angle ≈	weight ≈ (kg)
		H7	6H																
CFP5 M4	8-10	5	M4	8	6	7,7	18	9	11	11,11	27	10	36	4	10	9	600	13	0,02
CFP6 M6	12-16	6	M6	9	6,75	8,9	20	10	13	12,7	30	12	40	5	11	11	700	13	0,025
CFP8 M8	20	8	M8	12	9	10,4	24	12,5	16	15,87	36	16	48	5	13	14	1200	14	0,046
CFP10 M10x1,25	25-32	10	M10x1,25	14	10,5	12,9	28	15	19	19,05	43	20	57	6,5	15	17	1400	13	0,075
CFP12 M12x1,25	40-50	12	M12x1,25	16	12	15,4	32	17,5	22	22,22	50	22	66	6,5	17	19	1900	13	0,112
CFP16 M16x1,5	50-63	16	M16x1,5	21	15	19,3	42	22	27	28,57	64	28	85	8	23	22	4800	15	0,222
CFP20 M20x1,5	80-100	20	M20x1,5	25	18	24,3	50	27,5	34	34,92	77	33	102	10	27	30	5200	14	0,406
CFP25 M24x2	125	25	M24x2	31	22	29,5	60	33,5	42	42,85	94	42	124	12	32	36	8500	15	0,65
CFP30 M27x2	125	30	M27x2	37	25	34,8	70	40	50	50,8	110	51	145	15	36	41	10800	17	1,119
CFP35 M36x2	160-200	35	M36x2	43*	28	37,7*	80	46,0*	58*	57,15	125	56	165	17,0*	41	50	12400	16	1,595
CFP40 M42x2	250	40	M42x2	49*	33	45,1*	91	53	65*	66,6	142	60	187	19*	45	55	26000	16*	2,4
CFP50 M48x2	320	50	M48x2	60*	45	56,6*	117	65	75*	82,5	162	65	218	23*	58	65	30800	14*	5

*no standard dimension

For left-hand thread add "L" (ex. CFP_L8 M8)
 Technical reading from page 9 to page 15

MATERIAL

Support:

Up to size 12 automatic steel 1.1SMnPb30 (1.0718)
 from size 14 hardened and tempered steel C40 (1.1186),
 galvanized surface by passivation free from hexavalent
 chromium (EN ISO 4042, Fe/Zn 8c 1B)

Inner ring:

tempered, ground and
 polished steel for bearings
 100 Cr6 (1.3505)

Outer ring:

brass and PTFE
 bonded on the inner
 surface

DIN ISO 12240-4 Series K Female thread

Coupling: stainless steel/PTFE

Application: precision engineering, suitable for oxidizing and corrosive environments

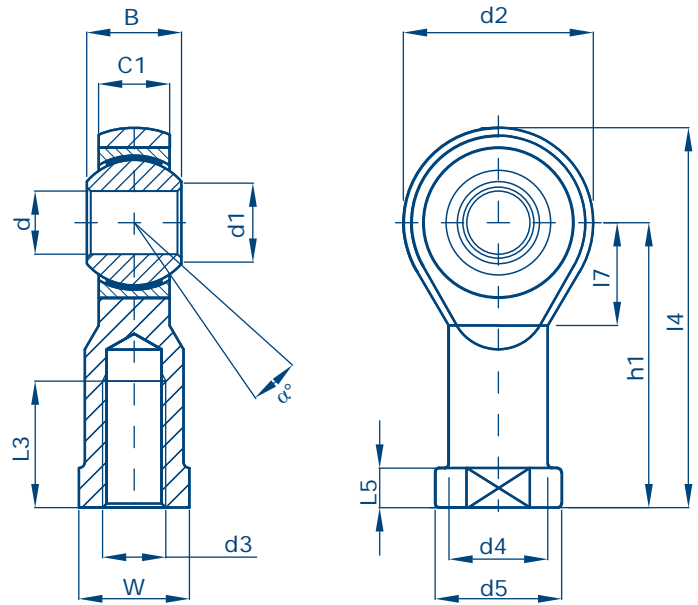

Dimensions mm

DESIGNATION	d	d3	B	C1	d1	d2	d4	d5	dk	h1	L3	L4	L5	L7	W	static radial load Co.(daN)	α° pivoting angle \approx	weight \approx (kg)
	H7	6H																
CFPX5 M5	5	M5	8	6	7,7	18	9	11	11	27	10	36	4	10	9	600	13	0,019
CFPX6 M6	6	M6	9	6,8	8,9	20	10	13	13	30	12	40		11	11	700	13	0,026
CFPX8 M8	8	M8	12	9	10,4	24	13	16	16	36	16	48	5	13	14	1200	14	0,046
CFPX10 M10	10	M10	14	11	12,9	28	15	19	19	43	20	57	6,5	15	17	1400	13	0,074
CFPX12 M12	12	M12	16	12	15,4	32	18	22	22	50	22	66	6,5	17	19	1900	13	0,111
CFPX14 M14	14	M14	19	14	16,8	36	20	25	25	57	25	75	8	19	22	3600	15	0,156
CFPX16 M16	16	M16	21	15	19,3	42	22	27	29	64	28	85	8	23	22	4800	15	0,231
CFPX18 M18x1,5	18	M18x1,5	23	17	21,8	46	25	31	32	71	32	94	10	25	27	5100	15	0,295
CFPX20 M20	20	M20	25	18	24,3	50	28	34	35	77	33	102	10	27	30	5200	14	0,402

For left-hand thread add "L" (ex. CFPXL8 M8)

Technical reading from page 9 to page 15

MATERIAL

Support:

stainless steel
X5CrNi1810
(1.4301 - AISI 304)

Inner ring:

stainless steel
X46Cr13
(1.4034 - AISI 420)

Outer ring:

stainless steel
X5CrNi1810
(1.4301 - AISI 304) with
PTFE bonded on the inner
surface

Series
CFPX

SELF-LUBRICATING ROD ENDS
STAINLESS STEEL Version

DIN ISO 12240-4 Series K Male thread

Coupling: stainless steel/PTFE

Application: precision engineering, suitable for oxidizing and corrosive environments

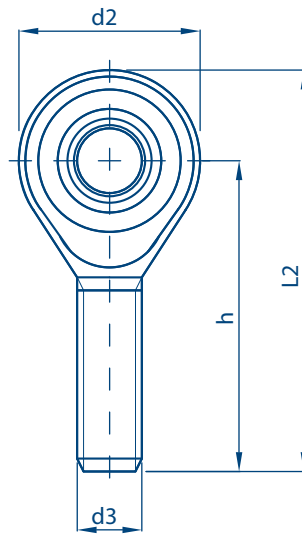
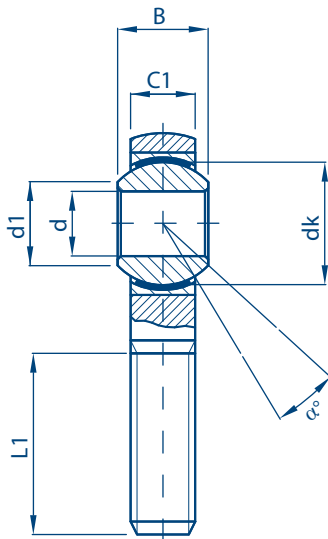

Series
CMPX

**SELF-LUBRICATING ROD ENDS
 STAINLESS STEEL Version**

Dimensions mm

DESIGNATION	d	d3	B	C1	d1	d2	dk	h	L1	L2	static radial load Co. (daN)	α° pivoting angle \approx	weight \approx (kg)
	H7	6g											
CMPX5 M5	5	M5	8	6	7,7	18	11,11	33	19	42	300	13	0,015
CMPX6 M6	6	M6	9	6,75	8,9	20	12,7	36	21	46	400	13	0,021
CMPX8 M8	8	M8	12	9	10,4	24	15,87	42	25	54	800	14	0,040
CMPX10 M10	10	M10	14	10,5	12,9	28	19,05	48	28	62	1300	13	0,064
CMPX12 M12	12	M12	16	12	15,4	32	22,22	54	32	70	1700	13	0,097
CMPX14 M14	14	M14	19	13,5	16,8	36	25,4	60	36	78	3600	15	0,13
CMPX16 M16	16	M16	21	15	19,3	42	28,57	66	37	87	4800	15	0,208
CMPX16 M16x1,5	16	M16x1,5	21	15	19,3	42	28,57	66	37	87	4800	15	0,208
CMPX18 M18x1,5	18	M18x1,5	23	16,5	21,8	46	31,75	72	41	95	5100	15	0,260
CMPX20 M20	20	M20	25	19	24,3	50	34,52	78	45	103	5200	14	0,367

For left-hand thread add "L" (ex. CMPXL8 M8)
 Technical reading from page 9 to page 15

MATERIAL

Support:

stainless steel
 X5CrNi1810
 (1.4301 - AISI 304)

Inner ring:

stainless steel
 X46Cr13
 (1.4034 - AISI 420)

Outer ring:

stainless steel
 X5CrNi1810
 (1.4301 - AISI 304) with
 PTFE bonded on the inner
 surface

DIN ISO 12240-4 Series K ISO 8139 (CETOP) Female thread for pneumatic cylinders

Coupling: stainless steel/PTFE

Application: precision engineering, suitable for oxidizing and corrosive environments

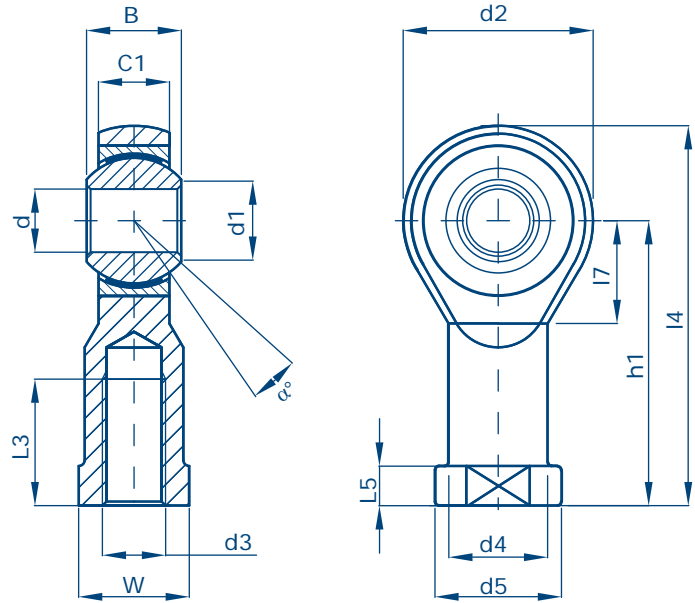

Dimensions mm

DESIGNATION	CYLINDER Ø	d H7	d3 6H	B	C1	d1	d2	d4	d5	dk	h	L3	L4	L5	L7	W	static radial load Co.(daN)	α ° pivoting angle ≈	weight ≈ (kg)
CFPX5 M4	8-10	5	M4	8	6	7,7	18	9	11	11,11	27	10	36	4	10	9	600	13	0,02
CFPX6 M6	12-16	6	M6	9	6,75	8,9	20	10	13	12,7	30	12	40	5	11	11	700	13	0,025
CFPX8 M8	20	8	M8	12	9	10,4	24	12,5	16	15,87	36	16	48	5	13	14	1200	14	0,046
CFPX10 M10x1,25	25-32	10	M10x1,25	14	10,5	12,9	28	15	19	19,05	43	20	57	6,5	15	17	1400	13	0,075
CFPX12 M12x1,25	40-50	12	M12x1,25	16	12	15,4	32	17,5	22	22,22	50	22	66	6,5	17	19	1900	13	0,112
CFPX16 M16x1,5	50-63	16	M16x1,5	21	15	19,3	42	22	27	28,57	64	28	85	8	23	22	4800	15	0,222
CFPX20 M20x1,5	80-100	20	M20x1,5	25	18	24,3	50	27,5	34	34,92	77	33	102	10	27	30	5200	14	0,406
CFPX25 M24x2	125	25	M24x2	31	22	29,5	60	33,5	42	42,85	94	42	124	12	32	36	8500	15	0,65
CFPX30 M27x2	125	30	M27x2	37	25	34,8	70	40	50	50,8	110	51	145	15	36	41	10800	17	1,119
CFPX35 M36x2	160-200	35	M36x2	43*	28	37,7*	80	46,0*	58*	57,15	125	56	165	17,0*	41	50	12400	16	1,595

For left-hand thread add "L" (ex. CFPXL8 M8)

Technical reading from page 9 to page 15

*no standard dimension

MATERIAL

Support:

stainless steel
X5CrNi1810
(1.4301 - AISI 304)

Inner ring:

stainless steel
X46Cr13
(1.4034 - AISI 420)

Outer ring:

stainless steel
X5CrNi1810
(1.4301 - AISI 304) with
PTFE bonded on the inner
surface

Series
CFPX

**SELF-LUBRICATING ROD ENDS
STAINLESS STEEL Version**

DIN ISO 12240-4 Series K Female thread

Coupling: steel/PTFE

Application: precision engineering

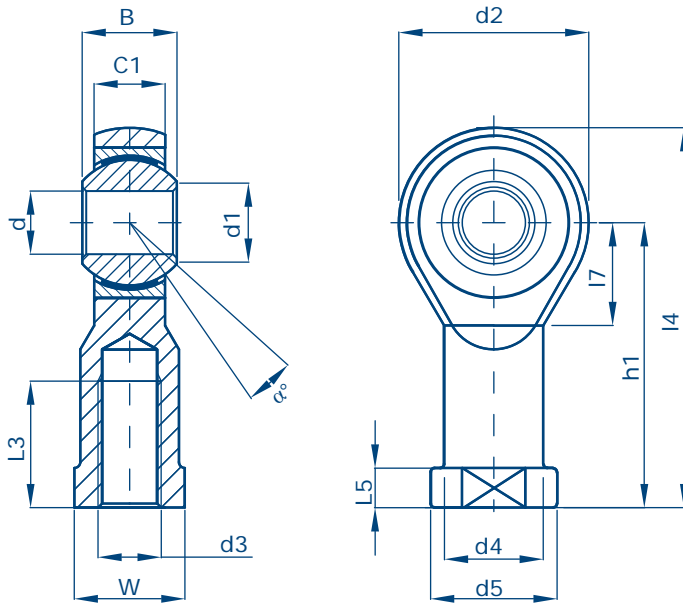

Series
CFE

SELF-LUBRICATING ROD ENDS
ERGAL Version

Dimensions mm

DESIGNATION	d	d3	B	C1	d1	d2	d4	d5	dk	h1	L3	L4	L5	L7	W	static radial load Co.(daN)	α° pivoting angle \approx	weight \approx (kg)
	H7	6H																
CFE 6 M6	6	M6	9	6,75	8,9	20	10	13	12,7	30	12	40	5	11	11	550	13	0,015
CFE 8 M8	8	M8	12	9	10,4	24	12,5	16	15,87	36	16	48	5	13	14	1200	14	0,037
CFE 10 M10	10	M10	14	10,5	12,9	28	15	19	19,05	43	20	57	6,5	15	17	1400	13	0,064
CFE 12 M12	12	M12	16	12	15,4	32	17,5	22	22,22	50	22	66	6,5	17	19	1900	13	0,098

*no standard dimension

For left-hand thread add "L" (ex. CFEL8 M8)
 Technical reading from page 9 to page 15

MATERIAL

Support:

ERGAL (alloy EN AW 7075 State T6) blue or purple anodized surface

Inner ring:

tempered, ground and polished steel for bearings
 100 Cr6 (1.3505)

Outer ring:

C45 (1.1191) carbon steel and PTFE bonded on the inner surface

DIN ISO 12240-4 Series K Male thread

Coupling: steel/PTFE

Application: precision engineering

Series
CME

SELF-LUBRICATING ROD ENDS
ERGAL Version

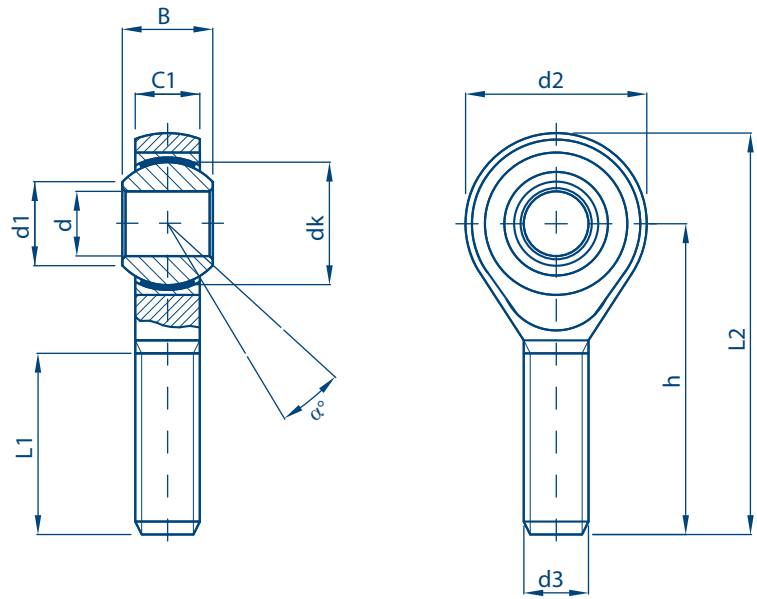

Dimensions mm

DESIGNATION	d	d3	B	C1	d1	d2	dk	h	L1	L2	static radial load Co. (daN)	α° pivoting angle \approx	weight \approx (kg)
	H7	6g											
CME 6 M6	6	M6	9	6,75	8,9	20	12,7	36	21	46	550	13	0,013
CME 8 M8	8	M8	12	9	10,4	24	15,87	42	25	54	800	14	0,035
CME 10 M10	10	M10	14	10,5	12,9	28	19,05	48	28	62	1300	13	0,058
CME 12 M12	12	M12	16	12	15,4	32	22,22	54	32	70	1700	13	0,087

For left-hand thread add "L" (ex. CME L8 M8)

Technical reading from page 9 to page 15

MATERIAL

Support:

ERGAL (alloy EN AW 7075 State T6) blue or purple anodized surface

Inner ring:

tempered, ground and polished steel for bearings 100 Cr6 (1.3505)

Outer ring:

C45 (1.1191) carbon steel and PTFE bonded on the inner surface

DIN ISO 12240-4 Series K Female thread

Coupling: stainless steel/PTFE

Application: precision engineering, suitable for oxidizing and corrosive environments

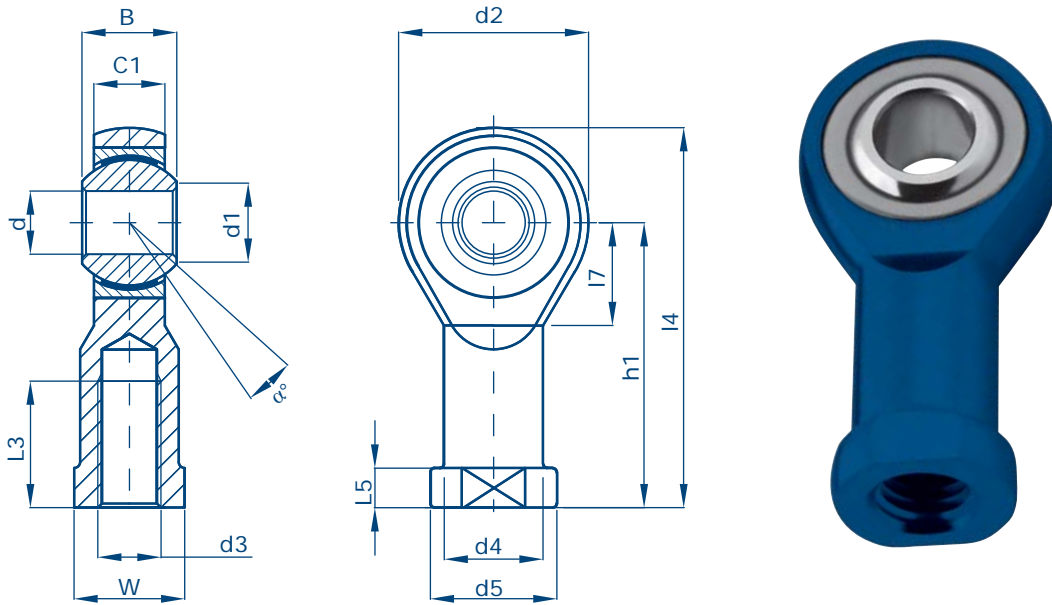

Series
CFEX

**SELF-LUBRICATING ROD ENDS
ERGAL - STAINLESS STEEL Version**

Dimensions mm

DESIGNATION	d	d3	B	C1	d1	d2	d4	d5	dk	h1	L3	L4	L5	L7	W	static radial load Co. (daN)	α° pivoting angle \approx	weight \approx (kg)
	H7	6H																
CFEX 6 M6	6	M6	9	6,75	8,9	20	10	13	12,7	30	12	40	5	11	11	550	13	0,015
CFEX 8 M8	8	M8	12	9	10,4	24	12,5	16	15,87	36	16	48	5	13	14	1200	14	0,037
CFEX 10 M10	10	M10	14	10,5	12,9	28	15	19	19,05	43	20	57	6,5	15	17	1400	13	0,064
CFEX 12 M12	12	M12	16	12	15,4	32	17,5	22	22,22	50	22	66	6,5	17	19	1900	13	0,098

For left-hand thread add "L" (ex. CFEXL8 M8)
 Technical reading from page 9 to page 15

MATERIAL

Support:

ERGAL (alloy EN AW 7075 State T6) blue or purple anodized surface

Inner ring:

stainless steel
 X40Cr14
 (1.4021 - AISI 420)

Outer ring:

stainless steel
 X5CrNi1810
 (1.4301 - AISI 304) with PTFE bonded on the inner surface

DIN ISO 12240-4 Series K Male thread

Coupling: stainless steel/PTFE

Application: precision engineering, suitable for oxidizing and corrosive environments

Series
CMEX

SELF-LUBRICATING ROD ENDS
ERGAL - STAINLESS STEEL Version

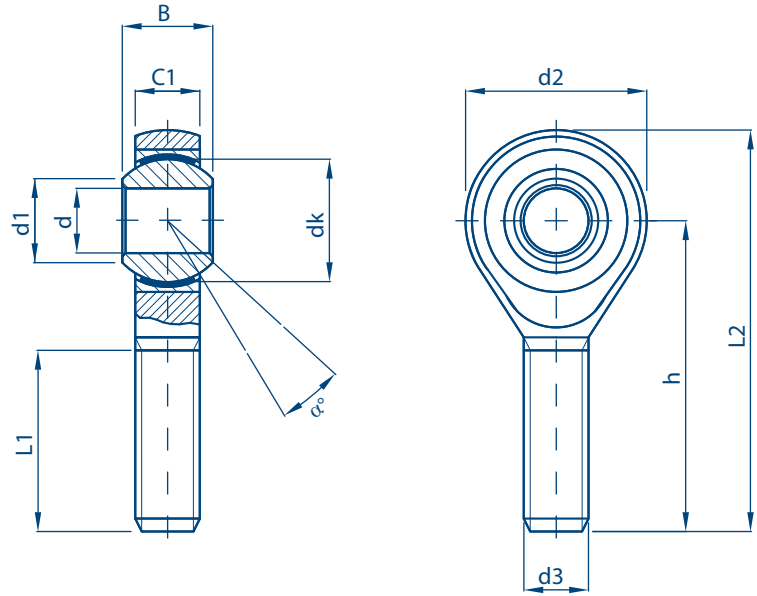

Dimensions mm

DESIGNATION	d	d3	B	C1	d1	d2	dk	h	L1	L2	static radial load Co.(daN)	α° pivoting angle \approx	weight \approx (kg)
	H7	6g											
CMEX 6 M6	6	M6	9	6,75	8,9	20	12,7	36	21	46	550	13	0,013
CMEX 8 M8	8	M8	12	9	10,4	24	15,87	42	25	54	800	14	0,035
CMEX 10 M10	10	M10	14	10,5	12,9	28	19,05	48	28	62	1300	13	0,058
CMEX 12 M12	12	M12	16	12	15,4	32	22,22	54	32	70	1700	13	0,087

For left-hand thread add "L" (ex. CMEXL8 M8)

Technical reading from page 9 to page 15

MATERIAL

Support:

ERGAL (alloy EN AW 7075 State T6) blue or purple anodized surface

Inner ring:

stainless steel X40Cr14 (1.4021 - AISI 420)

Outer ring:

stainless steel X5CrNi 1810 (1.4301 - AISI 304) with PTFE bonded on the inner surface

DIN ISO 12240-1 Series K

Coupling: steel/PTFE

Application: precision engineering

Series
SPK

SELF-LUBRICATING SPHERICAL BEARINGS
STANDARD Version

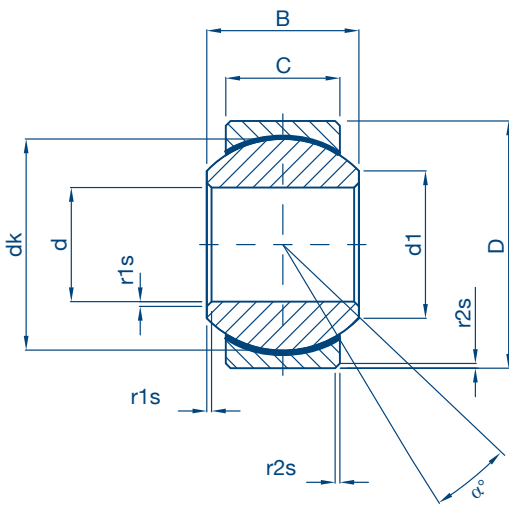

Dimensions mm

DESIGNATION	d	B	C	D	d1	dk	r1s	r2s	static radial load Co. (daN)	static axial load Co. (daN)	α° pivoting angle \approx	weight \approx (kg)	
	H7			h6			min.	min.					
SPK5	5	8	6	13	7,7	11,1	0,3	0,3	1300	170	13	0,006	
SPK6	6	9	6,75	16	8,9	12,7			1700	220	13	0,009	
SPK8	8	12	9	19	10,4	15,6			2800	370	14	0,016	
SPK10	10	14	10,5	22	12,9	19,1			4000	520	13	0,025	
SPK12	12	16	12	26	15,4	22,2			5300	700	13	0,04	
SPK14	14	19	13,5	28	16,8	25,4			8600	880	15	0,09	
SPK16	16	21	15	32	19,3	28,6			8500	1100	15	0,100	
SPK18	18	23	16,5	35	21,8	31,7			13100	1400	15	0,125	
SPK20	20	25	18	40	24,3	34,9			0,6	12500	1600	14	0,15
SPK22	22	28	20	42	25,8	38,1				19100	2100	15	0,21
SPK25	25	31	22	47	29,5	42,8				23600	2700	15	0,30
SPK30	30	37	25	55	34,8	50,8	25400	3300		17	0,38		
SPK35	35	43	28*	62*	37,7*	57,2*	0,6	1	32000	4150	19	0,49	
SPK40	40	49	35	75	44,2	66,6	0,6	1	48000	4800	16	0,900	
SPK50	50	60	45	90	55,8	82,5	0,6	1	80000	7900	14	1,600	

*no standard dimension

Technical reading from page 9 to page 15

MATERIAL

Inner ring:

tempered, ground and polished steel for bearings
 100Cr6 (1.3505)

Outer ring:

C45 (1.1191) carbon steel
 and PTFE bonded on the inner surface

DIN ISO 12240-1 Series K

Coupling: stainless steel/PTFE

Application: precision engineering, suitable for oxidizing and corrosive environments

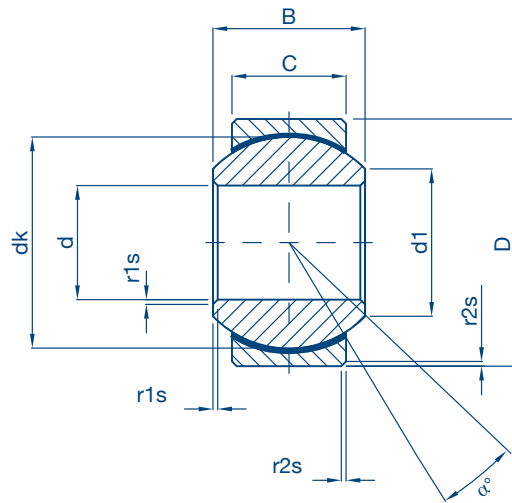

Dimensions mm

DESIGNATION	d H7	B	C	D	d1	dk	r1s min.	r2s min.	static radial load Co. (daN)	static axial load Co. (daN)	α° pivoting angle \approx	weight \approx (kg)		
SPKX5	5	8	6	13	7,7	11,1	0,3	0,3	1300	170	13	0,006		
SPKX6	6	9	6,75	16	8,9	12,7			1700	220	13	0,009		
SPKX8	8	12	9	19	10,4	15,6			2800	370	14	0,016		
SPKX10	10	14	10,5	22	12,9	19,1			4000	520	13	0,025		
SPKX12	12	16	12	26	15,4	22,2			5300	700	13	0,04		
SPKX14	14	19	13,5	28	16,8	25,4			8600	880	15	0,09		
SPKX16	16	21	15	32	19,3	28,6			8500	1100	15	0,08		
SPKX18	18	23	16,5	35	21,8	31,7			13100	1400	15	0,125		
SPKX20	20	25	18	40	24,3	34,9			0,6	0,6	12500	1600	14	0,15
SPKX22	22	28	20	42	25,8	38,1					19100	2100	15	0,21
SPKX25	25	31	22	47	29,5	42,8					23600	2700	15	0,30
SPKX30	30	37	25	55	34,8	50,8					25400	3300	17	0,38
SPKX35	35	43	28*	62*	37,7*	57,2*					0,6	1	32000	4150

Technical reading from page 9 to page 15

MATERIAL

Inner ring:

stainless steel X46Cr13
(1.4034 - AISI 420)

Outer ring:

stainless steel
X5CrNi1810
(1.4301 - AISI 304) with
PTFE bonded on the inner
surface

*no standard dimension

Series
SPKX

SELF-LUBRICATING SPHERICAL BEARINGS
STAINLESS STEEL Version

chiavette unificate





1. PRODUCT DESCRIPTION

Clevises are mechanical linking units suitable for the transmission of static forces. The pins or the lockable pins, used in conjunction with the clevises, have the function of connecting the clevis with the mechanical part for the transmission of the force. They are standard products, which are produced according to the norms and the indicated dimensional tables. All our products can be supplied galvanized or unplated.

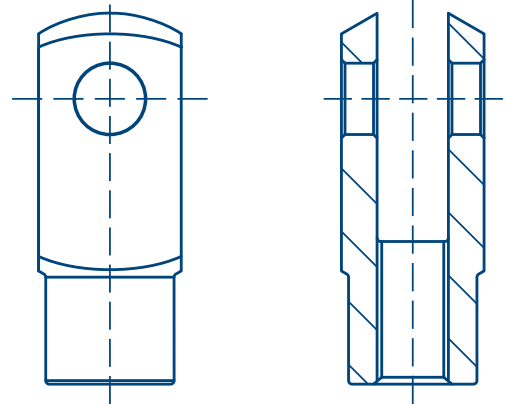

2. TECHNICAL DATA

- Clevis type G DIN 71752 norm
- Clevis type G . . FG DIN 71752 norm with thread ISO 8140
- Clevis type G . . CN t CNOMO 06 07 14 norm
- Mating piece for clevis type G . . FG according to dimensional tables
- Pin type PDIN DIN 1434 norm
- Pin type PKS according to dimensional tables
- Pin type PI according to dimensional tables
- Pin type PC according to dimensional tables

Material: Automatic Steel 11SMnPb30 (1.0718) COLD-DRAWN (+C) EN 10277-3 NORM

- Clevis type G . . STAINLESS STEEL DIN 71752 norm
- Clevis type G . . FG STAINLESS STEEL DIN 71752 norm with thread ISO 8140
- Mating piece for clevis type G . . FG STAINLESS STEEL according to dimensional tables
- Pin type PI . . STAINLESS STEEL according to dimensional tables

Material: Stainless Steel AISI 303 (1,4305) COLD-DRAWN (+C) EN 10088-3 NORM

- Clevis type GA . . DIN 71752 norm
- Clevis type GA . . FG DIN 71752 norm with thread ISO 8140
- Pin type PKSAL . . according to dimensional tables

Material: Aluminium 2011 (11S) anodized COLD-DRAWN EN 754 NORM

- Lockable pin type PM according to dimensional tables
- Lockable pins type PMC according to dimensional tables

Material: Pin - automatic steel 11SMnPb30 (1,0718)

Material: Spring - carbon steel C67 (1,0603)

Static load

By static load we mean the maximum radial load which, when applied to the forks in a static way, does not create permanent deformations or prejudice its functioning.

The values of the maximum permissible load were obtained by calculation and then verified on significant samples taken from our production series.

In the tables of dimensions the permissible static loads (C_o) which are indicated have been calculated on the basis of a minimum safety factor of 2.5 times with respect to the breaking static load.

Where pulsating or alternating loads are used, it is necessary to reduce the permissible static load introducing the safety coefficient K_f :

$$Fr \text{ amm.} = C_o \times K_f$$

- Fr amm.** = maximum permissible load on the fork (daN)
- C_o** = permissible radial static load on the fork (daN)
- K_f** = load coefficient
- Fr** = radial force applied (daN)

It is important always to verify the following condition:

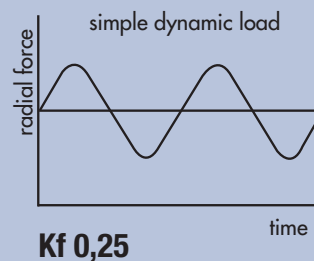
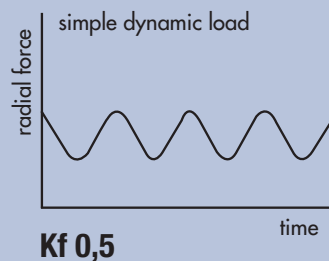
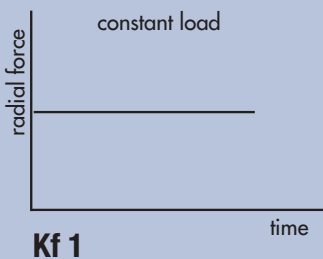

3. TOLERANCES

The constructional tolerances refer to current regulations or to those specified in the tables of dimensions.

DIN 71752

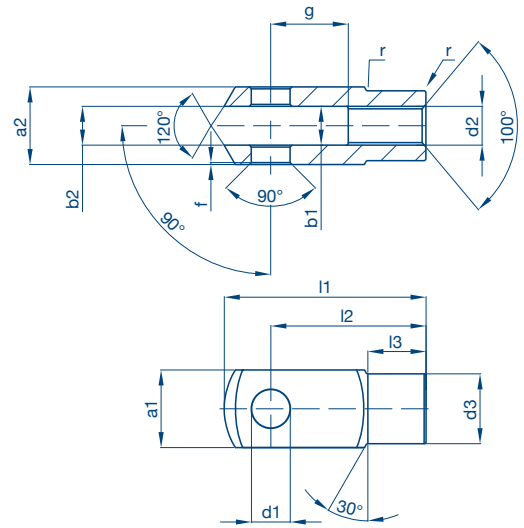

Dimensions mm

DESIGNATION	d1	g	a1	a2	b1	b2	d2	d3	f	l1	l2	l3	r	static load Co.(daN)	weight ≈ (kg)	
	H9	±0,5	h11	+0,30 -0,16	B13	tol.										Regular thread 6H
G4X8	4	8	8	8	4	4	M4x0,70	8	0,5	21	16	±0,3	6	0,5	320	0,005
G4X16	4	16	8	8	4	4	M4x0,70	8	0,5	29	24		6	0,5	32	0,007
G5X10	5	10	10	10	5	5	M5x0,80	9	0,5	26	20	±0,3	7,5	0,5	500	0,009
G5X20	5	20	10	10	5	5	M5x0,80	9	0,5	36	30		7,5	0,5	500	0,013
G6X12	6	12	12	12	6	6	M6x1,00	10	0,5	31	24	±0,3	9	0,5	720	0,015
G6X24	6	24	12	12	6	6	M6x1,00	10	0,5	43	36		9	0,5	720	0,022
G8X16	8	16	16	16	8	8	M8x1,25	14	0,5	42	32	±0,3	12	0,5	1280	0,037
G8X16 FG	8	16	16	16	8	8	M8x1,00	14	0,5	42	32		12	0,5	1280	0,037
G8X32	8	32	16	16	8	8	M8x1,25	14	0,5	58	48	±0,3	12	0,5	1280	0,054
G8X32 FG	8	32	16	16	8	8	M8x1,00	14	0,5	58	48		12	0,5	1280	0,054
G10X20	10	20	20	20	10	10	M10x1,50	18	0,5	52	40	±0,3	15	0,5	2000	0,074
G10X20 FG	10	20	20	20	10	10	M10x1,25	18	0,5	52	40		15	0,5	2000	0,074
G10X40	10	40	20	20	10	10	M10x1,50	18	0,5	72	60	±0,4	15	0,5	2000	0,116
G10X40 FG	10	40	20	20	10	10	M10x1,25	18	0,5	72	60		15	0,5	2000	0,116
G12X24	12	24	24	24	12	12	M12x1,75	20	0,5	62	48	±0,4	18	0,5	2880	0,121
G12X24 FG	12	24	24	24	12	12	M12x1,25	20	0,5	62	48		18	0,5	2880	0,121
G12X48	12	48	24	24	12	12	M12x1,75	20	0,5	86	72	±0,4	18	0,5	2880	0,175
G12X48 FG	12	48	24	24	12	12	M12x1,25	20	0,5	86	72		18	0,5	2880	0,175
G14X28	14	28	27	27	14	14	M14x2,00	24	1	72	56	±0,4	22,5	1	3380	0,178
G14X28 FG	14	28	27	27	14	14	M14x1,50	24	1	72	56		22,5	1	3380	0,178
G14X56	14	56	27	27	14	14	M14x2,00	24	1	101	85	±0,4	22,5	1	3380	0,258
G14X56 FG	14	56	27	27	14	14	M14x1,50	24	1	101	85		22,5	1	3380	0,258
G16X32	16	32	32	32	16	16	M16x2,00	26	1	83	64	±0,4	24	1	5120	0,282
G16X32 FG	16	32	32	32	16	16	M16x1,50	26	1	83	64		24	1	5120	0,282
G16X64	16	64	32	32	16	16	M16x2,00	26	1	115	96	±0,4	24	1	5120	0,411
G16X64 FG	16	64	32	32	16	16	M16x1,50	26	1	115	96		24	1	5120	0,411

For left-hand thread add "LH" (ex. G16x32 LH)
 Technical reading from page 44 to page 45

MATERIAL

automatic steel 11SMnPb30 (1.0718)

Surface protection:

- Zinc plating according to EN ISO 4042, Fe/Zn 8c...
- Chromate treatment (passivation) example: type A please add 1A (G20x40 1A)
- Surface treatment table at page 6
- Without any indication, the clevis will be supplied oiled and unplated

Tolerances:

The dimensional tolerances shown in the table make reference to zinc plated products.

Series
G

CLEVISES

chiavette unificate

Similar to DIN 71752 (measures not included in the standard)

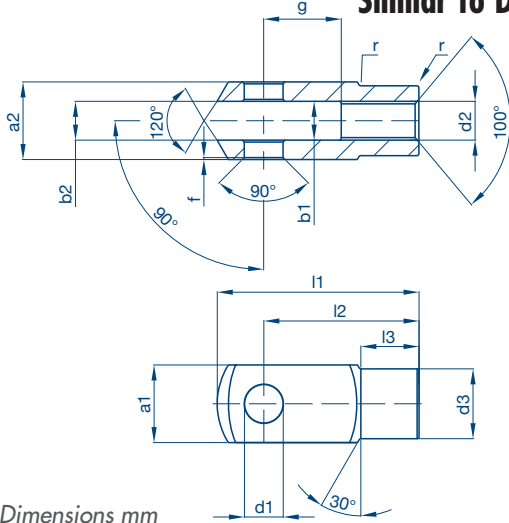

Series

G

CLEVISES

Dimensions mm

DESIGNATION	d1	g	a1	a2	b1	b2	d2		d3	f	l1	l2	l3	r	static load Co.(daN)	weight ≈ (kg)
	H9	±0,5	h11	+0,30 -0,16	B13	Tol.	regular thread 6H	fine pitch thread 6H	±0,3	±0,2	±0,5	Tol.	±0,2			
G18X36	18	36	36	36	18	18	M18x2,50		30	1	94	72	27	1,5	6480	(kg)
G18X36 FG	18	36	36	36	18	18		M18x1,5	30	1	94	72	27	1,5	6480	0,39
G20X40	20	40	40	40	20	20	M20x2,50		34	1	105	80	30	1,5	8000	0,55
G20X40 FG	20	40	40	40	20	20		M20x1,50	34	1	105	80	30	1,5	8000	0,55
G20X80	20	80	40	40	20	20	M20x2,50		34	1	145	120	30	1,5	8000	0,80
G20X80 FG	20	80	40	40	20	20		M20x1,50	34	1	145	120	30	1,5	8000	0,80
G25X50	25	50	50	50	25	25	M24x3,00		42	1	132	100	36	1,5	12500	1,10
G25X50 FG	25	50	50	50	25	25		M24x2,00	42	1	132	100	36	1,5	12500	1,10
G30X54	30	54	55	55	30	30	M30x3,50		48	1	148	110	38	2	12500	1,46
G30X54 FG	30	54	55	55	30	30		M30x2,00	48	1	148	110	38	2	12500	1,46
G35X72	35	72	70	70	35	35	M36x4,00		60	1	188	144	40	3	24500	3,27
G35X72 FG	35	72	70	70	35	35		M36x2,00	60	1	188	144	40	3	24500	3,27
G42X84	42	84	85	85	42	42	M42x4,50		70	3	232	168	63,5	5	35500	5,30
G42X84 FG	42	84	85	85	42	42		M42x2,00	70	3	232	168	63,5	5	35500	5,30
G50X96 FG	50	96	96	96	50	50		M48x2,00	82	3	265	192	73	5	41000	7,90

For left-hand thread add "LH" (ex. G20x40 LH)
 Technical reading from page 44 to page 45

MATERIAL

automatic steel 11SMnPb30 (1.0718)

Surface protection:

- Zinc plating according to EN ISO 4042, Fe/Zn 8c...
- Chromate treatment (passivation) example: type A please add 1A (G20x40 1A)
- Surface treatment table at page 6
- Without any indication, the clevis will be supplied oiled and unplated

Tolerances:

The dimensional tolerances shown in the table make reference to zinc plated products.

DIN 71752 Thread ISO 8140 CETOP for pneumatic cylinders

Series
G/FG

CLEVISSES

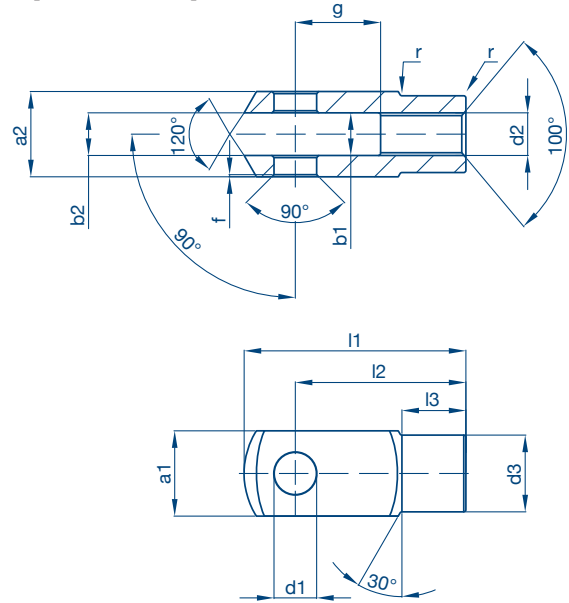

Dimensions mm

DESIGNATION	CYLINDER Ø	d1	g	a1	a2	b1	b2	d2	d3	f	l1	l2	l3	r	static load Co.(daN)	weight ≈ (kg)	
		H9	±0,5	h11	+0,30 -0,16	B13	Tol.	6H	±0,3	±0,2	±0,5	Tol.	±0,2				
G4X8	8-10	4	8	8	8	4	B13	M4x0,70	8	0,5	21	16	±0,3	6	0,5	320	0,005
G6X12	12-16	6	12	12	12	6		M6x1,00	10	0,5	31	24		9	0,5	720	0,015
G8X16	20	8	16	16	16	8		M8x1,25	14	0,5	42	32	±0,4	12	0,5	1280	0,036
G10X20 FG	25-32	10	20	20	20	10		M10x1,25	18	0,5	52	40		15	0,5	2000	0,070
G12X24 FG	40	12	24	24	24	12	M12x1,25	20	0,5	62	48	18		0,5	2880	0,121	
G16X32 FG	50-63	16	32	32	32	16	+0,70 +0,15	M16x1,50	26	1	83	64	24	1	5120	0,250	

similar to DIN 71752 (sizes not considered in the norm)

DESIGNATION	CYLINDER Ø	d1	g	a1	a2	b1	b2	d2	d3	f	l1	l2	l3	r	static load Co.(daN)	weight ≈ (kg)	
		H9	±0,5	h11	+0,30 -0,16	B13	Tol.	6H	±0,3	±0,2	±0,5	Tol.	±0,2				
G20X40 FG	80-100	20	40	40	40	20	+0,70 +0,15	M20x1,50	34	1	105	80	±0,4	30	1,5	8000	0,550
G25X50 FG	125	25	50	50	50	25		M24x2,00	42	1	132	100		36	1,5	12500	1,100
G30X54 FG	125	30	54	55	55	30		M27x2,00	48	1	148	110		38	2	12500	1,460
G35X72 FG	160-200	35	72	70	70	35		M36x2,00	60	1	188	144	40	3	24500	3,270	
G40X84 FG	250	40	84	85	85	40		M42x2,00	70	3	232	168	63,5	5	39000	5,300	
G42X84 FG	250	42	84	85	85	42		M42x2,00	70	3	232	168		63,5	5	35500	5,300
G50X96 FG	320	50	96	96	96	50	M48x2,00	82	3	265	192	73	5	41000	7,900		

For left-hand thread add "LH" (ex. G16x32 FG LH)
Technical reading from page 44 to page 45

MATERIAL

automatic steel 11SMnPb30 (1.0718)

Surface protection:

- Zinc plating according to EN ISO 4042, Fe/Zn 8c...
- Chromate treatment (passivation) example: type A please add 1A (G16x32 FG 1A)
- Surface treatment table at page 6
- Without any indication, the clevis will be supplied oiled and unplated

Tolerances:

The dimensional tolerances shown in the table make reference to zinc plated products.

Former CNOMO 06-07-14

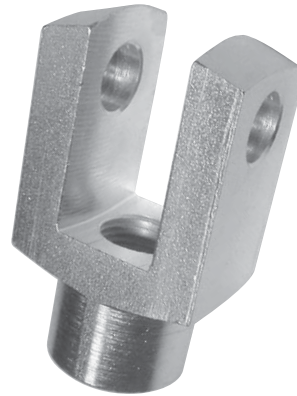
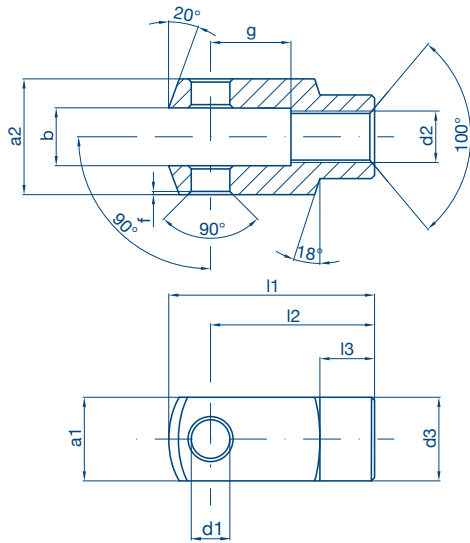

Series
G/CN

CLEVISES

Dimensions mm

DESIGNATION	CYLINDER Ø	d1	g	a1	a2	b	d2	d3	f	l1	l2	l3	static load Co.(daN)	weight ≈ (kg)
		H9	±0,5	h11	h11	H11	6H	±0,3	±0,2	±0,5	±0,4	±0,2		
G8x16 CN	32	8	16	22	22	11	M10x1,5	18	0,5	45	36	14	3080	0,080
G12x25 CN	40-50	12	25	26	36	18	M16x1,5	26	0,5	64	51	17	5040	0,210
G16x33 CN	63-80	16	33	34	45	22	M20x1,5	34	1	80	63	18,5	8280	0,440
G20x40 CN	100-125	20	40	42	63	30	M27x2,0	42	1	105	85	30	14520	0,910
G25x40 CN	160-200	25	40	50	80	40	M36x2,0	50	1	140	115	45	20000	1,800

For left-hand thread add "LH" (ex. G20x40 CN LH)
Technical reading from page 44 to page 45

MATERIAL

automatic steel 11SMnPb30 (1.0718)

Surface protection:

- Zinc plating according to EN ISO 4042, Fe/Zn 8c...
- Chromate treatment (passivation) example: type A please add 1A (G16x33 CN 1A)
- Surface treatment table at page 6
- Without any indication, the clevis will be supplied oiled and unplated

Tolerances:

The dimensional tolerances shown in the table make reference to zinc plated products.

DIN 71752

Series
G
INOX

CLEVISES
STAINLESS STEEL Version

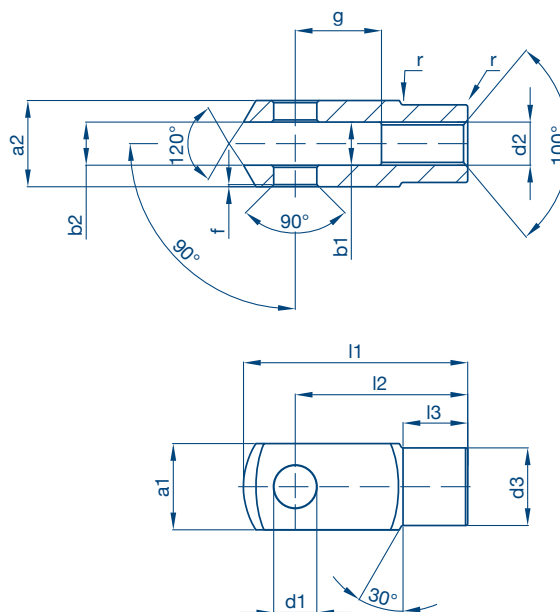

Dimensions mm

DESIGNATION	d1	g	a1	a2	b1	b2	d2	d3	f	l1	l2	l3	r	static load Co.(daN)	weight ≈ (kg)
	H9	±0,5	h11	+0,30 -0,16	B13	tol.	6H	±0,3	±0,2	±0,5	tol.	±0,2			
G5x10 INOX	5	10	10	10	5	5	M5x0,80	9	0,5	26	20	7,5	0,5	500	0,009
G5x20 INOX	5	20	10	10	5	5	M5x0,80	9	0,5	36	30	7,5	0,5	500	0,013
G6x12 INOX	6	12	12	12	6	6	M6x1,00	10	0,5	31	24	9	0,5	720	0,015
G6x24 INOX	6	24	12	12	6	6	M6x1,00	10	0,5	43	36	9	0,5	720	0,022
G8x16 INOX	8	16	16	16	8	8	M8x1,25	14	0,5	42	32	12	0,5	1280	0,036
G8x32 INOX	8	32	16	16	8	8	M8x1,25	14	0,5	58	48	12	0,5	1280	0,054
G10x20 INOX	10	20	20	20	10	10	M10x1,50	18	0,5	52	40	15	0,5	2000	0,074
G10x40 INOX	10	40	20	20	10	10	M10x1,50	18	0,5	72	60	15	0,5	2000	0,116
G12x24 INOX	12	24	24	24	12	12	M12x1,75	20	0,5	62	48	18	0,5	2880	0,121
G12x48 INOX	12	48	24	24	12	12	M12x1,75	20	0,5	86	72	18	0,5	2880	0,175
G16x32 INOX	16	32	32	32	16	16	M16x2,00	26	1	83	64	24	1	5120	0,282
G16x64 INOX	16	64	32	32	16	16	M16x2,00	26	1	115	96	24	1	5120	0,411

Similar to DIN 71752 (sizes not considered in the norm)

DESIGNATION	d1	g	a1	a2	b1	b2	d2	d3	f	l1	l2	l3	r	static load Co.(daN)	weight ≈ (kg)
	H9	±0,5	h11	+0,30 -0,16	B13	tol.	6H	±0,3	±0,2	±0,5	tol.	±0,2			
G20x40 INOX	20	40	40	40	20	20	M20x2,50	34	1	105	80	30	1,5	8000	0,550
G30x54 INOX	30	54	55	55	30	30	M30x3,50	48	1	148	110	38	2	12500	1,460
G35x72 INOX	35	72	70	70	35	35	M36x4,00	60	1	188	144	40	3	24500	3,270

For left-hand thread add "LH" (ex. G16x32 LH INOX)

Technical reading from page 44 to page 45

chiavette unificate

MATERIAL

stainless steel (1.4305 - AISI 303)

DIN 71752 thread according to ISO 8140 CETOP for pneumatic cylinders

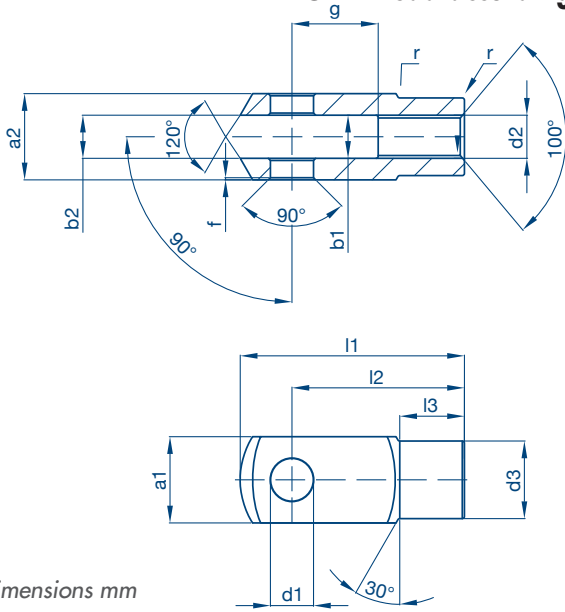

Series
G/FG
INOX

CLEVISES
STAINLESS STEEL Version

Dimensions mm

DESIGNATION	CYLINDER Ø	d1	g	a1	a2	b1	b2	d2	d3	f	l1	l2	l3	r	static load Co.(daN)	weight ≈ (kg)			
		H9	±0,5	h11	0,3 -0,16	B13		6H	±0,3	±0,2	±0,5		Tol.	±0,2					
G4X8 INOX	8-10	4	8	8	8	4	4	M4x0,70	8	0,5	21	16	±0,3	6	320	0,005			
G6X12 INOX	12-16	6	12	12	12	6	6		M6x1,00	10	0,5	31		24			9	720	0,015
G8X16 INOX	20	8	16	16	16	8	8		M8x1,25	14	0,5	42		32			12	1280	0,036
G10X20 FG INOX	25-32	10	20	20	20	10	10	M10x1,25	18	0,5	52	40	±0,4	15	2000	0,070			
G12X24 FG INOX	40	12	24	24	24	12	12		M12x1,25	20	0,5	62		48			18	2880	0,121
G16X32 FG INOX	50-63	16	32	32	32	16	16		M16x1,50	26	1	83		64			24	5120	0,250

Similar to DIN 71752 (measures not included in the standard)

DESIGNATION	CYLINDER Ø	d1	g	a1	a2	b1	b2	d2	d3	f	l1	l2	l3	r	static load Co.(daN)	weight ≈ (kg)			
		H9	±0,5	h11		B13	Tol.	6H	±0,3	±0,2	±0,5		±0,2						
G20X40 FG INOX	80-100	20	40	40	40	20	20	M20x1,50	34	1	105	80	±0,4	30	8000	0,550			
G30X54 FG INOX	125	30	54	55	55	30	30		M27x2,00	48	1	148		110			38	12500	1,460
G35X72 FG INOX	160-200	35	72	70	70	35	35		M36x2,00	60	1	188		144			40	24500	3,270

For left-hand thread add "LH" (ex. G16x32 FG LH INOX)
Technical reading from page 44 to page 45

MATERIAL

stainless steel (1.4305 - AISI 303)

chiavette unificate



Rotating Clevises similar to DIN 71752

Series
GR

CLEVISES

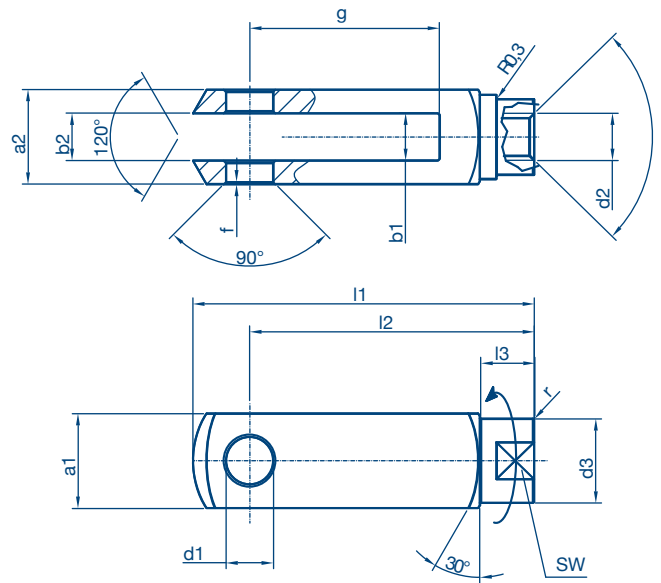

Dimensions mm

DESIGNATION	d1	g	a1	a2	b1	b2	d2	d3	f	l1	l2	l3	SW	static load Co.(daN)	weight ≈ (kg)	
	H9	±0,5	h11	+0,30 -0,16	B13	tol.	6H	±0,3	±0,2	±0,5	tol.	±0,2				
GR5x10	5	10	10	10	5	B13	M5x0,80	8,8	0,5	26	±0,30	4	7	80	0,014	
GR5x20	5	20	10	10	5		M5x0,80	8,8	0,5	36		30	4	7	80	0,023
GR6x12	6	12	12	12	6		M6x1,00	10,2	0,5	31		24	5,6	9	240	0,015
GR6x24	6	24	12	12	6		M6x1,00	10,2	0,5	43	36	±0,40	5,6	9	240	0,040
GR8x16	8	16	16	16	8		M8x1,25	14	0,5	42	32		8,2	12	340	0,036
GR8x32	8	32	16	16	8		M8x1,25	14	0,5	58	48		8,2	12	340	0,102
GR10x20	10	20	20	20	10	+0,70 +0,15	M10x1,50	17,8	0,5	52	40	±0,40	11,8	16	600	0,070
GR10x40	10	40	20	20	10		M10x1,50	17,8	0,5	72	60		11,8	16	600	0,186
GR12x24	12	24	24	24	12		M12x1,75	20	0,5	62	48	14	18	1400	0,121	
GR12x48	12	48	24	24	12		M12x1,75	20	0,5	86	72	14	18	1400	0,325	

Technical reading from page 44 to page 45

MATERIAL

automatic steel 11SMnPb30 (1.0718)

Surface protection:

- Zinc plating according to EN ISO 4042, Fe/Zn 8c...
- Exemple of chromate treatment (passivation): type A please add 1A (G16x32 1A)
- Surface treatment table at page 6
- With no indications the clevis will be supplied oiled and unplated.

Tolerances:

The dimensional tolerances shown in the table make reference to zinc plated products.

Clevises with elongated hole similar to DIN 71752

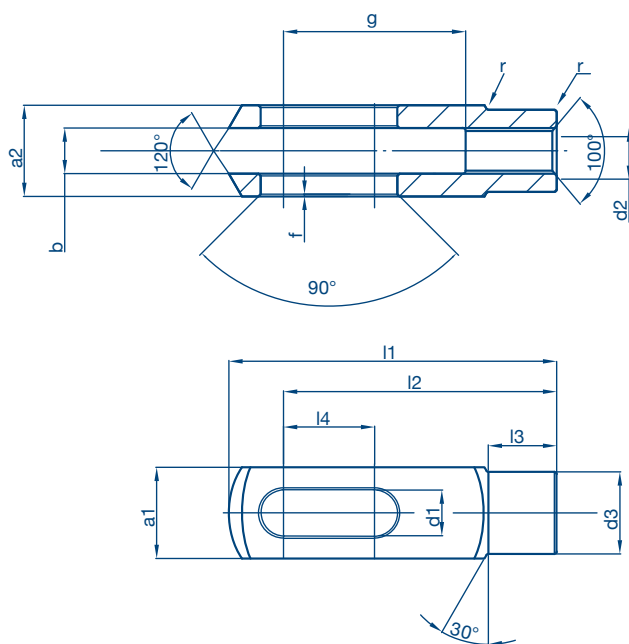

Series
GS

CLEVISES

Dimensions mm

DESIGNATION	d1	g	a1	a2	b	d2		d3	f	l1	l2	l3	l4	r	static load Co.(daN)	weight ≈ (kg)
	+0,20 0	±0,5	h11	+0,50 -0,16	+0,70 +0,15	regular thread 6H	fine pitch thread 6H	±0,3	±0,2	±0,5	±0,4	±0,2	±0,5			
GS6X24	6,1	24	12	12	6	M6x1,00		10	0,5	43	36	9	12	0,5	720	0,022
GS8X32	8,1	32	16	16	8	M8x1,25		14	0,5	58	48	12	16	0,5	1280	0,054
GS8X32 FG	8,1	32	16	16	8		M8x1	14	0,5	58	48	12	16	0,5	1280	0,054
GS10X40	10,1	40	20	20	10	M10x1,50		18	0,5	72	60	15	20	0,5	2000	0,116
GS10X40 FG	10,1	40	20	20	10		M10x1,25	18	0,5	72	60	15	20	0,5	2000	0,116
GS12X48	12,1	48	24	24	12	M12x1,75		20	0,5	86	72	18	24	0,5	2880	0,175
GS12X48 FG	12,1	48	24	24	12		M12x1,25	20	0,5	86	72	18	24	0,5	2880	0,175
GS14X56	14,1	56	27	27	14	M14x2,00		24	1	101	85	22,5	28	1	3380	0,258
GS14X56 FG	14,1	56	27	27	14		M14x1,5	24	1	101	85	22,5	28	1	3380	0,258
GS16X64	16,1	64	32	32	16	M16x2,00		26	1	115	96	24	32	1	5120	0,411
GS16X64 FG	16,1	64	32	32	16		M16x1,50	26	1	115	96	24	32	1	5120	0,411

For left-hand thread add "LH" (ex. GS16x64 LH)
Technical reading from page 44 to page 45

MATERIAL

automatic steel 11SMnPb30 (1.0718), on request stainless steel (1.4305 - AISI 303)

Surface protection:

- Zinc plating according to EN ISO 4042, Fe/Zn 8c...
- Exemple of chromate treatment (passivation): type A please add 1A (G16x641A)
- Surface treatment table at page 6
- With no indications the clevis will be supplied oiled and unplated.

Tolerances:

The dimensional tolerances shown in the table make reference to zinc plated products.

DIN 71752

Series
GA

CLEVISES
ALUMINIUM Version

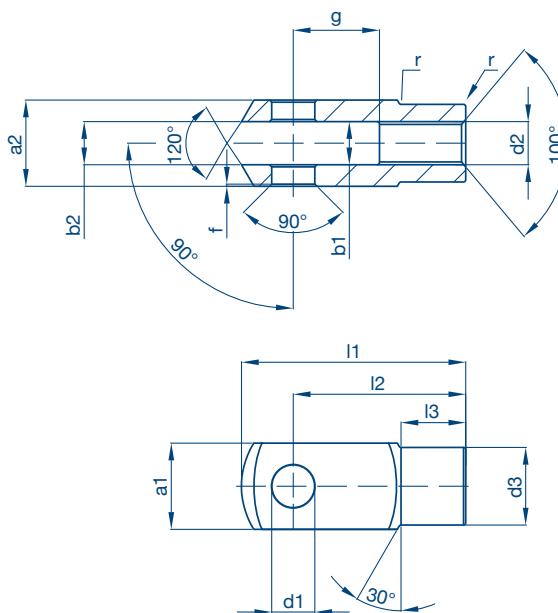

Dimensions mm

DESIGNATION	d1	g	a1	a2	b1	b2	d2		d3	f	l1	l2	l3	r	static load Co.(daN)	weight ≈ (kg)			
	H9	±0,5	h11	+0,30 -0,16	B13	Tol.	regular thread 6H	fine pitch thread 6H	±0,3	±0,2	±0,5	Tol.	±0,2						
GA4x8	4	8	8	8	4	4	B13	M4x0,70		8	0,5	21	16	±0,30	6	0,5	190	0,001	
GA5x10	5	10	10	10	5	5		M5x0,80		9	0,5	26	20		7,5	0,5	300	0,003	
GA6x12	6	12	12	12	6	6		M6x1,00		10	0,5	31	24		9	0,5	430	0,005	
GA8x16	8	16	16	16	8	8		M8x1,25		14	0,5	42	32		12	0,5	760	0,012	
GA10x20	10	20	20	20	10	10		M10x1,50		18	0,5	52	40		15	0,5	1200	0,023	
GA10x20 FG	10	20	20	20	10	10			M10x1,25	18	0,5	52	40		15	0,5	1200	0,023	
GA12x24	12	24	24	24	12	12	+0,70 +0,15	M12x1,75		20	0,5	62	48	±0,40	18	0,5	1720	0,040	
GA12x24 FG	12	24	24	24	12	12			M12x1,25	20	0,5	62	48		18	0,5	1720	0,040	
GA16x32	16	32	32	32	16	16			M16x2,00		26	1	83		64	24	1	3070	0,085
GA16x32 FG	16	32	32	32	16	16			M16x1,5	26	1	83	64		24	1	3070	0,085	

similar to DIN 71752 (sizes not considered in the norm)

DESIGNATION	d1	g	a1	a2	b1	b2	d2		d3	f	l1	l2	l3	r	static load rad. Co.(daN)	weight ≈ (kg)		
	H9	±0,5	h11	+0,30 -0,16	B13	Tol.	regular thread 6H	fine pitch thread 6H	±0,3	±0,2	±0,5	Tol.	±0,2					
GA20x40	20	40	40	40	20	20	+0,70 +0,15	M20x2,50		34	1	105	80	±0,40	30	1,5	4800	0,185
GA20x40 FG	20	40	40	40	20	20			M20x1,50	34	1	105	80		30	1,5	4800	0,185

For left-hand thread add "LH" (ex. GA16x32 LH)
Technical reading from page 44 to page 45

MATERIAL

aluminium 2011 (11S)

Surface protection:

Silver colour anodizing.

Upon request:

- Gold Colour
- Black Colour

DIN 71752 thread according to ISO 8140 CETOP for pneumatic cylinders

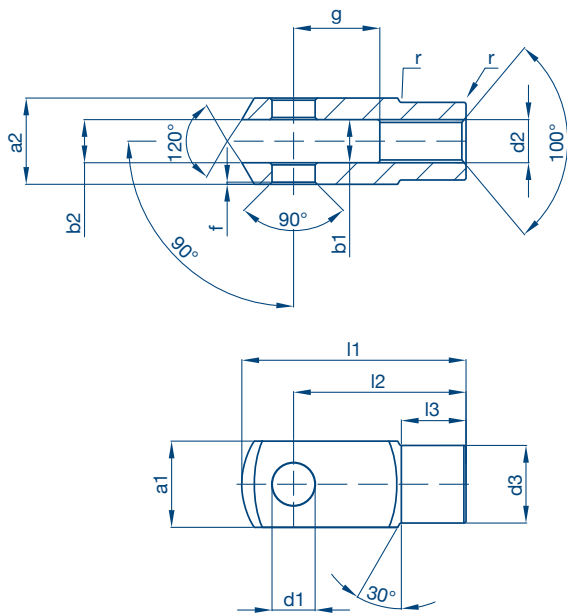

Series
GA/FG

CLEVISES
ALUMINIUM Version

Dimensions mm

DESIGNATION	CYLINDER Ø	d1	g	a1	a2	b1	b2	d2	d3	f	l1	l2	l3	r	static load Co.(daN)	weight ≈ (kg)									
		H9	±0,5	h11	+0,3 -0,16	B13	Tol.	6H	±0,3	±0,2	±0,5	Tol.	±0,2												
GA4X8	8-10	4	8	8	8	4	4	M4x0,70	8	0,5	21	16	6	0,5	190	0,001									
GA6x12	12-16	6	12	12	12	6	6										M6x1,00	10	0,5	31	24	9	0,5	430	0,005
GA8x16	20	8	16	16	16	8	8																		
GA10x20 FG	25-32	10	20	20	20	10	10										M10x1,25	18	0,5	52	40	15	0,5	1200	0,023
GA12x24 FG	40	12	24	24	24	12	12	M12x1,25	20	0,5	62	48	18	0,5	1720	0,040									
GA16x32 FG	50-63	16	32	32	32	16	16																		

similar to DIN 71752 (sizes not considered in the norm)

DESIGNATION	CYLINDER Ø	d1	g	a1	a2	b1	b2	d2	d3	f	l1	l2	l3	r	static load Co.(daN)	weight ≈ (kg)
		H9	±0,5	h11	+0,3 -0,16	B13	Tol.	6H	±0,3	±0,2	±0,5	Tol.	±0,2			
G20X40 FG	80-100	20	40	40	40	20	20	M20x1,50	34	1	105	80	30	1,5	4800	0,185

For left-hand thread add "LH" (ex. GA16x32 FG LH)
Technical reading from page 44 to page 45

MATERIAL

aluminium 2011 (11S)

Surface protection:

Silver colour anodizing.

Upon request:

- Gold Colour
- Black Colour

Series
AG

MATING PIECE FOR CLEVISES

Mating piece for clevises

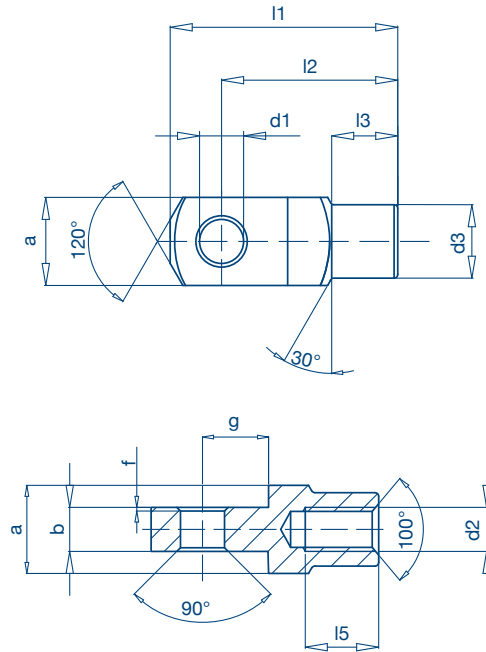

Dimensions mm

DESIGNATION	d1	g	a	b	d2		d3	f	l1	l2	l3	l5	weight ~ (kg)
					Regular thread 6H	Fine pitch thread 6H							
	H9	±0,5	h11	0 -0,2			±0,3	±0,2	±0,5	±0,30	±0,2	min	
AG4	4	6	8	4	M4x0,70		8	0,5	21	16	6	6	0,006
AG5	5	7,5	10	5	M5x0,80		9	0,5	26	20	7,5	8	0,010
AG6	6	9	12	6	M6x1,00		10	0,5	31	24	9	11	0,017
AG8	8	12	16	8	M8x1,25		14	0,5	42	32	12	14	0,040
AG10	10	15	20	10	M10x1,50		18	0,5	52	40	15	18	0,080
AG10 FG	10	15	20	10		M10x1,25	18	0,5	52	40	15	18	0,080
AG12	12	18	24	12	M12x1,75		20	0,5	62	48	18	22	0,130
AG12 FG	12	18	24	12		M12x1,25	20	0,5	62	48	18	22	0,130
AG14	14	21	27	14	M14x2,00		24	1	72	56	22,5	25	0,210
AG14 FG	14	21	27	14		M14x1,50	24	1	72	56	22,5	25	0,210
AG16	16	24	32	16	M16x2,00		26	1	83	64	24	30	0,320
AG16 FG	16	24	32	16		M16x1,5	26	1	83	64	24	30	0,320
AG20	20	30	40	20	M20x2,5		34	1	105	80	30	38	0,660
AG20 FG	20	30	40	20		M20x1,5	34	1	105	80	30	38	0,660

For left-hand thread add "LH" (ex. AG16 LH)
Technical reading from page 44 to page 45

MATERIAL

automatic steel 11SMnPb30 (1.0718) upon request stainless steel (1.4305 - AISI 303)

Surface protection:

- Zinc plating according to EN ISO 4042, Fe/Zn 8c...
- Chromate treatment (passivation) example: type A please add 1A (AG16 1A)
- Surface treatment table at page 6
- Without any indication, the clevis will be supplied oiled and unplated

Tolerances:

The dimensional tolerances shown in the table make reference to zinc plated products.

Lockable pins for clevises series G, GFG e GA

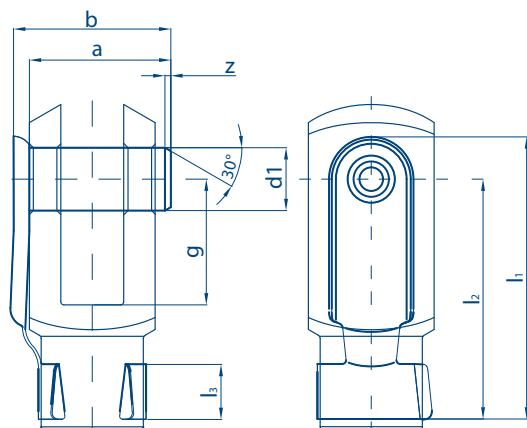

Series
PM

CLEVIS ACCESSORIES

Dimensions mm

DESIGNATION	d1 h11	g ±0,5	b	a ±0,2	l1 ≈	l2 ≈	l3 ≈	z	weight ≈ (kg)
PM4x8	4	8	11	9	19	15	4,5	0,5	0,002
PM5x10	5	10	13,5	12	23	19	4,5	0,5	0,003
PM5x20	5	20	13,5	12	33	29	4,5	0,5	0,003
PM6x12	6	12	16	14	28	23	6	0,75	0,005
PM6x24	6	24	16	14	40	35	6	0,75	0,005
PM8x16	8	16	22	19	37	31	8	1	0,011
PM8x32	8	32	22	19	53	47	8	1	0,012
PM10x20	10	20	26	23	46	39	10	1	0,019
PM10x40	10	40	26	23	66	59	10	1	0,020
PM12x24	12	24	32	28	55	46	12	1,25	0,032
PM12x48	12	48	32	28	79	71	12	1,25	0,034
PM14x28	14	28	34	31	62	52	14	1,5	0,047
PM14x56	14	56	34	31	92	82	14	1,5	0,051
PM16x32	16	32	41	36	72	62	14	1,5	0,067
PM16x64	16	64	40	36	103	92	16	1,5	0,075
PM20x40	20	40	49	44	88	72	16	1,5	0,130

MATERIAL

Pin: automatic steel 11SMnPb30 (1.0718)

Spring: carbon steel C67 (1.1231) hardened and tempered

Surface protection:

- Zinc plating according to standard EN ISO 4042, Fe/Zn 8c..., with dehydrogenation
- Chromate treatment (passivation) example: type A please add 1A (PM16x32 1A)
- Surface treatment table at page 6
- With no indications the lockable pin will be supplied oiled and unplated

Tolerances:

The dimensional tolerances shown in the table make reference to zinc plated products.

Lockable pins for former CNOMO yokes series G/CN

Series
PMC

CLEVIS ACCESSORIES

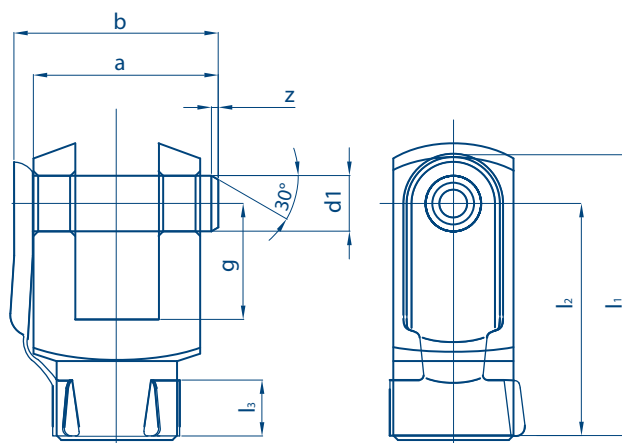

Dimensions mm

DESIGNATION	d1	g	b	a	l1	l2	l3	z	weight ≈ (kg)
PMC 8x16	h11	±0,5		±0,2	≈	≈	≈		
PMC 8x16	8	16	28	25	41	36	10	1	0,014
PMC 12x25	12	25	44	40	60	50	12	1,25	0,043
PMC 16x33	16	33	53	49	74	63	15	1,5	0,090
PMC 20x40	20	40	73	69	98	81	19	1,5	0,193

MATERIAL

Pin: automatic steel 11SMnPb30 (1.0718)

Spring: carbon steel C67 (1.1231) hardened and tempered

Surface protection:

- Zinc plating according to standard EN ISO 4042, Fe/Zn 8c..., with dehydrogenation
- Chromate treatment (passivation) example: type A please add 1A (PMC16x33 1A)
- Surface treatment table at page 6
- Without any indication, the lockable pin will be supplied oiled and unplated

Tolerances:

The dimensional tolerances shown in the table make reference to zinc plated products.

DESIGNATION	d	D	k	z	z1	r	d2	l1	l	weight ≈ (kg)
	h11	h12	js14	≈	max		H14	+0,50 0	+0,50 0	
PD 4	4	6	1,0	0,5	0,8	0,3	1,0	10,0	12	0,001
PD 5	5	8	1,5	0,5	0,8	0,3	1,5	12,0	15	0,001
PD 6	6	9	1,5	0,5	1,0	0,5	1,6	15,0	18	0,004
PD 8	8	12	2,0	1,0	1,0	0,5	2,0	19,5	23	0,009
PD 10	10	14	2,0	1,0	1,5	0,5	3,2	24,5	29	0,017
PD 12	12	17	3,0	1,5	2,0	0,5	4,0	29,5	35	0,030
PD 14	14	19	3,0	1,5	2,5	1,0	4,0	32,5	40	0,048
PD 16	16	21	3,0	1,5	2,5	1,0	4,0	37,5	45	0,067
PD 18	18	23	3,0	1,5	2,5	1,0	5,0	43,5	50	0,108
PD 20	20	26	4,0	2,0	3,0	1,0	5,0	47,0	54	0,125
PD 25	25	32	5,0	2,0	3,0	1,0	6,0	59,0	67	0,260
PD 30	30	36	5,0	2,0	3,0	1,0	6,3	63,0	71	0,430
PD 35	35	44	6,0	2,0	4,0	2,0	8,0	80,0	90	0,740
PD 42	42	48	6,0	2,0	4,0	2,0	8,0	98,0	108	1,259
PD 50	50	58	7,0	2,0	6,0	2,0	10,0	111,0	123	2,021

DESIGNATION	d1 ≈	d2 ≈	s ≈	weight (kg x 100 pcs.)
PDR 4	4,3	7,5	0,8	0,019
PDR 5	5,3	9,5	1,0	0,038
PDR 6	6,4	11,0	1,6	0,079
PDR 8	8,4	15,0	1,6	0,152
PDR 10	10,5	18,0	1,6	0,211
PDR 12	13,0	20,0	2,0	0,285
PDR 14	15,0	24,0	2,0	0,433
PDR 16	17,0	27,0	2,0	0,542
PDR 20	21,0	33,0	2,5	0,998
PDR 25	25,0	39,0	4,0	2,209
PDR 30	31,0	56,0	4,0	5,361
PDR 35	37,0	66,0	5,0	9,203
PDR 42	42,0	78,0	7,0	18,635
PDR 50	50,0	92,0	8,0	29,401

DESIGNATION	l ≈	u max	e ≈	b max	a max
PDC4	10	1,0	2,5	1,5	0,9
PDC 5/6	10	2,0	3,3	2,0	1,3
PDC 8	15	2,0	4,0	2,3	1,8
PDC 10	20	2,0	5,0	3,0	2,7
PDC 12/16	30	3,0	7,2	4,1	3,7
PDC 18/20	40	3,0	8,2	4,7	4,7
PDC 25/30	40	3,0	10,2	5,7	5,7
PDC 35/42	60	3,0	13,5	7,7	7,7
PDC 50	70	4,0	17,0	9,7	9,7

MATERIAL

Pin: automatic steel 11SMnPb30 (1.0718)

Surface protection:

- Zinc plating according to standard EN ISO 4042, Fe/Zn 8c..., with dehydrogenation
- Example of chromate treatment (passivation): type A please add 1A (ex.:PD10 1A)
- Surface treatments table at page 6
- With no indications the pin will be supplied oiled and unplated

Tolerances:

The dimensional tolerances shown in the table make reference to zinc plated products.

Pins DIN 1434

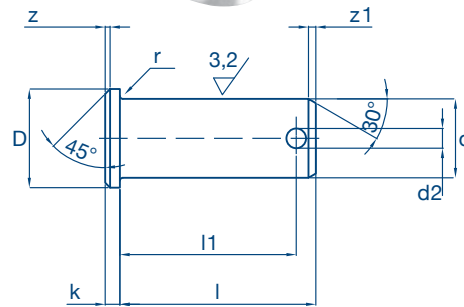

Washers DIN 433 or equivalent

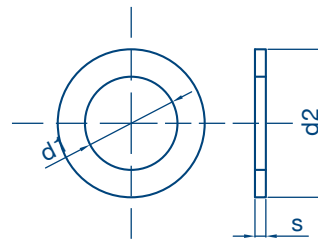

The values marked on the table are purely as an indication.

Split pins DIN 94

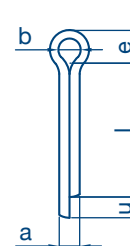

Series
PD

CLEVIS ACCESSORIES

Series
PDR

Series
PDC

chiavette unificate

Pins for yokes G, G/FG series

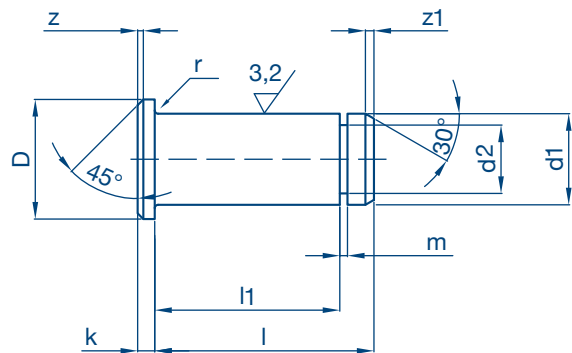

Dimensions mm

DESIGNATION	d1	D	k	z	z1	r	d2	m	l1	l	weight ≈ (kg)
	h11	h12	js14	≈	≈		h11	+0,10 0	+0,30 0	+0,30 0	
PKS 4	4	6	1,0	0,5	0,5	0,3	3,2	0,64	8,5	10,5	0,002
PKS 5	5	8	1,5	0,5	0,5	0,5	4,0	0,74	10,5	13,0	0,003
PKS 6	6	9	1,5	0,5	0,8	0,5	5,0	0,74	12,5	15,5	0,004
PKS 8	8	12	2,0	1,0	1,0	0,5	6,0	0,94	16,5	20,0	0,009
PKS10	10	14	2,0	1,0	1,0	0,5	8,0	1,05	20,5	25,0	0,017
PKS12	12	17	3,0	1,5	1,3	0,5	9,0	1,15	24,5	30,0	0,030
PKS14	14	19	3,0	1,5	1,5	1,0	10,0	1,25	27,5	33,0	0,048
PKS16	16	20	3,0	1,5	1,5	1,0	12,0	1,35	32,5	38,5	0,067
PKS20	20	26	4,0	2,0	1,5	1,0	17,5	1,80	40,5	46,0	0,125
PKS25	25	32	5,0	2,0	1,5	1,0	18,0	1,80	50,5	57,0	0,260

Technical reading from page 44 to page 45

MATERIAL

automatic steel 11SMnPb30 (1.0718)

Surface protection:

- Zinc plating according to standard EN ISO 4042, Fe/Zn 8c...
- Chromate treatment (passivation) example: type A please add 1A (es.:PKS10 1A)
- Surface treatment table at page 6
- without any indication, the lockable pin will be supplied oiled and unplated

Tolerances:

The dimensional tolerances shown in the table make reference to zinc plated products.

Pins in aluminium 11S for clevises series GA

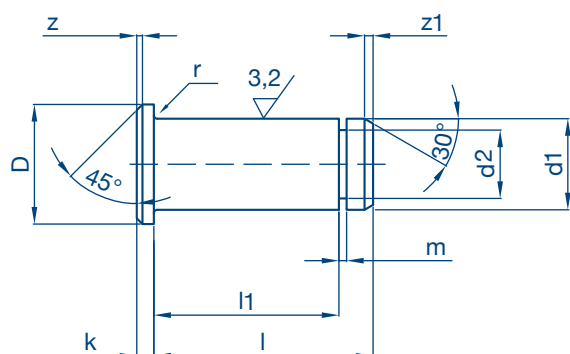

Series
PKSAL

CLEVIS ACCESSORIES
ALUMINIUM Version

Dimensions mm

DESIGNATION	d1	D	k	z	z1	r	d2	m	l1	l	weight ≈ (kg)
	h11	h12	js14	≈	≈		h11	+0,10 0	+0,30 0	+0,30 0	
PKSAL 4	4	6	1,0	0,5	0,5	0,3	3,2	0,64	8,5	10,5	0,001
PKSAL 5	5	8	1,5	0,5	0,5	0,5	4,0	0,74	10,5	13,0	0,001
PKSAL 6	6	9	1,5	0,5	0,8	0,5	5,0	0,74	12,5	15,5	0,002
PKSAL 8	8	12	2,0	1,0	1,0	0,5	6,0	0,94	16,5	20,0	0,003
PKSAL10	10	14	2,0	1,0	1,0	0,5	8,0	1,05	20,5	25,0	0,006
PKSAL12	12	17	3,0	1,5	1,3	0,5	9,0	1,15	24,5	30,0	0,010
PKSAL16	16	20	3,0	1,5	1,5	1,0	12,0	1,35	32,5	38,5	0,023
PKSAL20	20	26	4,0	2,0	1,5	1,0	17,5	1,80	40,5	46,0	0,042

Technical reading from page 44 to page 45

MATERIAL

aluminium 2011 (11S)

Surface protection:

Silver colour anodizing.

Upon request:

- Gold Colour
- Black Colour

SL retainers for pins "PKS" and "PKSAL"

Series

SL

CLEVIS ACCESSORIES

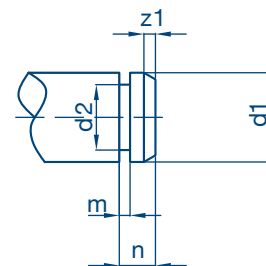
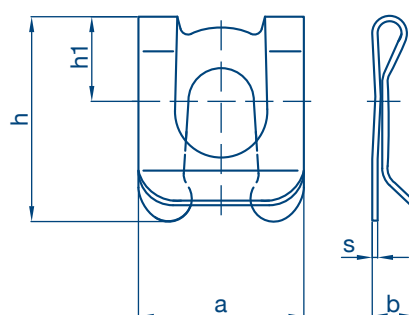

Dimensions mm

DESIGNATION	d1	a	h	h1	b	s	d2	m	n	z1	max axial load max x PKS [daN]	max axial load max x PKSAL [daN]	weight for 100 pcs [kg]
	h11	≈	≈	≈	≈		h11	+0,10 0	+0,30 0	≈			
SL 4	4	7	8,5	4,0	2,3	0,3	3,2	0,64	2,0	0,5	100	50	0,019
SL 5	5	9	10,7	5,0	3,3	0,4	4,0	0,74	2,5	0,5	130	65	0,034
SL 6	6	11	14,1	6,0	3,8	0,4	5,0	0,74	3,0	0,8	150	75	0,063
SL 8	8	14	17,5	8,0	4,0	0,5	6,0	0,94	3,5	1,0	360	180	0,109
SL10	10	18	22,1	10,0	5,0	0,5	8,0	1,05	4,5	1,0	640	320	0,211
SL12	12	22	26,0	12,0	5,0	0,5	9,0	1,15	5,0	1,3	960	480	0,280
SL14	14	25	30,0	13,5	6,0	0,6	10,0	1,25	5,5	1,5	1132	560	0,474
SL16	16	28	34,0	16,0	6,0	0,6	12,0	1,35	6,0	1,5	1350	670	0,563

MATERIAL

Spring steel

Surface protection:

- Zinc plating according to standard EN ISO 4042, Fe/Zn 8c...
- Chromate treatment (passivation) example: type A please add 1A (ex.: SL12 1A)

Tolerances:

The dimensional tolerances shown in the table are referred to zinc plated products.

chiavette unificate



KL retainers for pins "PKS" and "PKSAL"

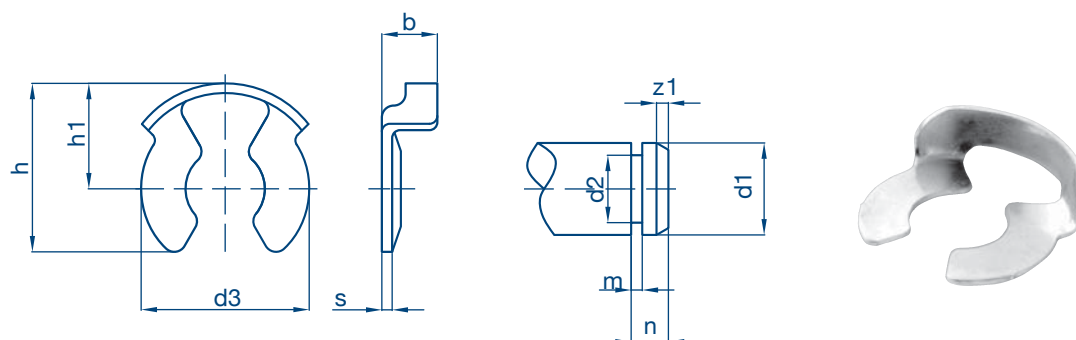

Series
KL

CLEVIS ACCESSORIES

Dimensions mm

DESIGNATION	d1	d3	h	h1	b	s	d2	m	n	z1	max axial load max x PKS [daN]	max axial load max x PKSAL [daN]	weight for 100 pcs [kg]
	h11	≈	≈	≈	≈		h11	+0,10 0	+0,30 0	≈			
KL 4	4	6,5	7,0	4,3	2,7	0,4	3,2	0,64	2,0	0,5	150	50	0,0109
KL 5	5	7,5	8,7	5,2	2,8	0,5	4,0	0,74	2,5	0,5	300	65	0,0195
KL 6	6	10,4	11,5	6,8	3,5	0,5	5,0	0,74	3,0	0,8	485	75	0,0332
KL 8	8	11,5	12,1	7,2	4,1	0,5	6,0	0,94	3,5	1,0	550	180	0,0408
KL10	10	15,6	16,3	9,5	5,9	0,6	8,0	1,05	4,5	1,0	950	320	0,0899
KL12	12	16,7	18,0	10,5	6,1	0,6	9,0	1,15	5,0	1,3	1070	480	0,1102
KL14	14	19,0	20,0	11,5	6,5	0,7	10,0	1,25	5,5	1,5	1270	560	0,1578
KL16	16	22,7	23,5	13,8	7,8	0,8	12,0	1,35	6,0	1,5	1400	670	0,2282
KL20	20-25	34,5	34,0	20,0	9,0	1,0	16-18	1,80	8,0	1,5	1600	720	0,6171

MATERIAL

Spring steel

Surface protection:

- Zinc plating according to standard EN ISO 4042, Fe/Zn 8c...
- Exemple of chromate treatment (passivation): type A please add 1A (ex.: KL12 1A)

Tolerances:

The dimensional tolerances shown in the table are referred to zinc plated products.

Series
PC

CLEVIS ACCESSORIES

Former CNOMO pins

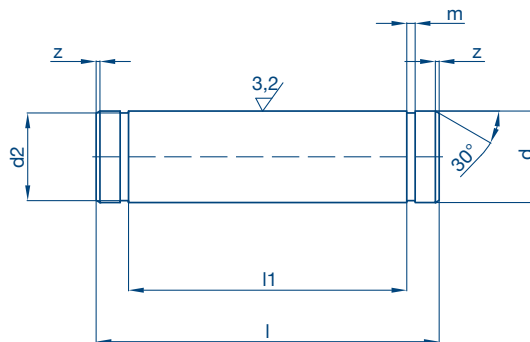

Dimensions mm

DESIGNATION	d1 h11	l +0,40 0	d2 h11	l1 +0,20 0	z min	m H13	weight ≈ (kg)
PC 8	8	30	7,60	22	0,5	0,9	0,012
PC 12	12	45	11,50	36	0,5	1,1	0,039
PC 16	16	55	15,20	45	0,5	1,1	0,085
PC 20	20	75	19,00	63	1,0	1,3	0,185
PC 25	25	95	23,90	80	1,0	1,3	0,360

MATERIAL

automatic steel 11SMnPb30 (1.0718)

Surface protection:

- Zinc plating according to standard EN ISO 4042, Fe/Zn 8c...
- Chromate treatment (passivation) example: type A please add 1A (es.: PC12 1A 1A)
- Surface treatment table at page 6
- Without any indication, the lockable pin will be supplied oiled and unplated

Tolerances:

The dimensional tolerances shown in the table make reference to zinc plated products.

Circlips DIN 471

Series
SE

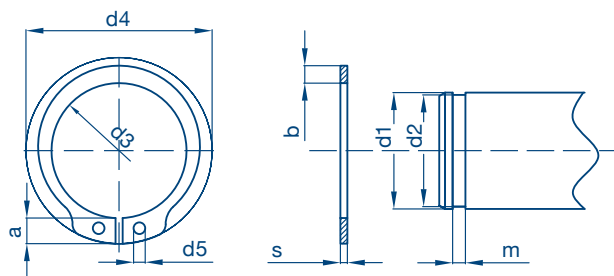

Dimensions mm

DESIGNATION	s	d3 ≈	d4	d5 min	a max	b ≈
SE 8	0,8	7,4	14,7	1,2	3,2	1,5
SE12	1,0	11,0	19,0	1,7	3,3	1,8
SE16	1,0	14,7	23,8	1,7	3,7	2,2
SE20	1,2	18,5	28,4	2,0	4,0	2,6
SE25	1,2	23,2	34,2	2,0	4,4	3,0

MATERIAL

carbon steel for springs Ck 75 (1.1248)

Supplied unplated

chiavette unificate



Pins ISO

Dimensions mm

DESIGNATION	d1	l	d2	l1	z	m	weight ≈ (kg)
	h11	+0,50 0	h11	+0,20 0	min	H13	
PI 6	6	17	5,7	12,5	0,5	0,8	0,005
PI 8	8	20	7,6	16,5	0,5	0,9	0,008
PI10	10	25	9,6	20,5	0,5	1,1	0,015
PI12	12	30	11,5	24,5	1	1,1	0,026
PI14	14	35	13,4	27,5	1	1,1	0,042
PI16	16	39	15,2	32,5	1	1,1	0,061
PI20	20	48	19	40,5	1	1,3	0,118
PI25	25	60	23,9	50,5	1	1,3	0,230
PI30	30	65	28,6	55,5	1	1,6	0,350
PI35	35	84	33,4	70,5	1	1,6	0,620
PI40	40	104,3	37,5	89,0	2	1,85	1,020
PI42	42	104,3	39,5	89,0	2	1,85	1,100
PI50	50	117,3	47	100	2	2,15	1,720

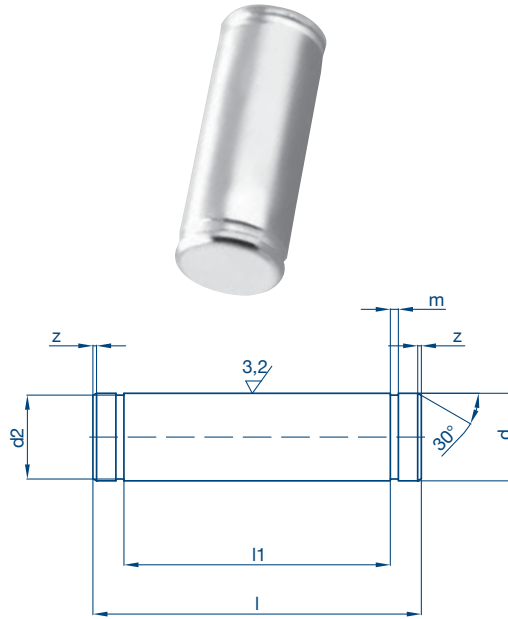

MATERIAL

automatic steel 11SMnPb30 (1.0718)

Surface protection:

- Zinc plating according to standard EN ISO 4042, Fe/Zn 8c ...
- Exemple of chromate treatment (passivation): type A please add 1A (ex.: PI 12 1A)
- Surface treatments table at page 6
- With no indications the pin will be supplied oiled and unplated

Tolerances:

The dimensional tolerances shown in the table make reference to zinc plated products.

Series

PI

CLEVIS ACCESSORIES

Dimensions mm

DESIGNATION	s	d3	d4	d5	a	b
	h11	≈		min	max	≈
SE 6	0,7	5,6	11,7	1,15	2,7	1,3
SE 8	0,8	7,4	14,7	1,20	3,2	1,5
SE10	1,0	9,3	17,0	1,50	3,3	1,8
SE12	1,0	11	19,0	1,70	3,3	1,8
SE14	1,0	12,9	21,4	1,70	3,5	2,1
SE16	1,0	14,7	23,8	1,70	3,7	2,2
SE20	1,2	18,5	28,4	2,00	4,0	2,6
SE25	1,2	23,2	34,2	2,00	4,4	3,0
SE30	1,5	27,9	40,5	2,00	5,0	3,5
SE35	1,5	32,2	46,8	2,50	5,6	3,9
SE40	1,8	36,5	52,6	2,50	6,0	4,4
SE42	1,8	38,5	55,7	2,50	6,5	4,5
SE50	2,0	45,8	64,5	2,50	6,9	5,1

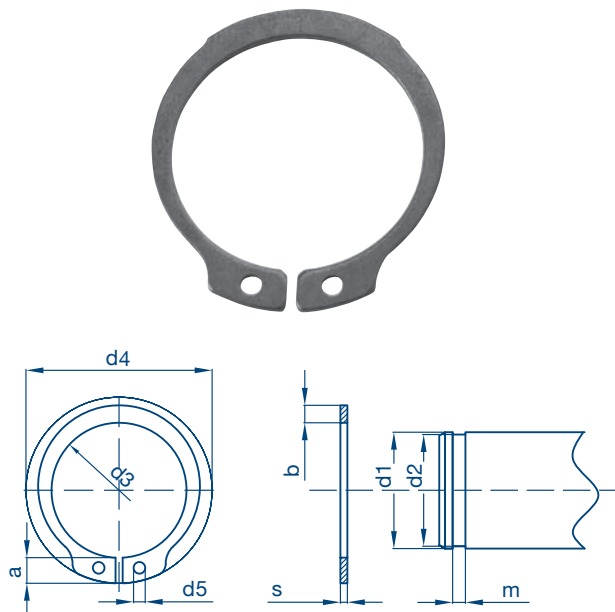

Circlips DIN 471

Series

SE

chiavette unificate

MATERIAL

carbon steel for springs Ck 75 (1.1248)

Series
**PI
INOX**

CLEVIS ACCESSORIES
STAINLESS STEEL Version

Series
**SE
INOX**

chiavette unificate



ISO Pins

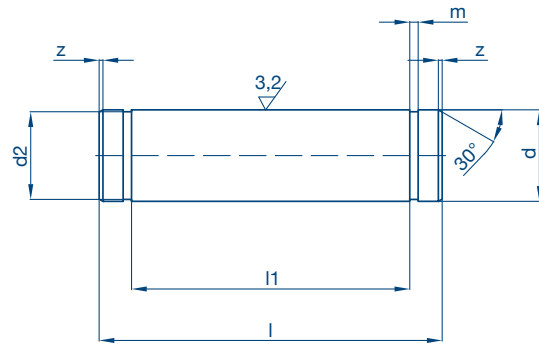

Dimensions mm

DESIGNATION	d1 h11	l +0,50 0	d2 h11	l1 +0,20 0	z min	m h13	weight ≈ (kg)
PI 5 INOX	5	15	4,8	10,5	0,5	0,7	0,003
PI 6 INOX	6	17	5,7	12,5	0,5	0,8	0,005
PI 8 INOX	8	20	7,6	16,5	0,5	0,9	0,008
PI 10 INOX	10	25	9,6	20,5	0,5	1,1	0,015
PI 12 INOX	12	30	11,5	24,5	1,0	1,1	0,026
PI 16 INOX	16	39	15,2	32,5	1,0	1,1	0,061
PI 20 INOX	20	48	19	40,5	1,0	1,3	0,118
PI 30 INOX	30	65	28,6	55,5	1,0	1,6	0,350
PI 35 INOX	35	84	33,4	70,5	1,0	1,6	0,620

MATERIAL

stainless steel (1.4305 - AISI 303)

Circlips DIN 471

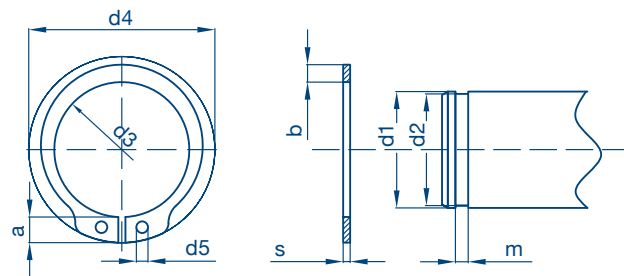

Dimensions mm

DESIGNATION	s h11	d3 ≈	d4	d5 min	a max	b ≈
SE 5 INOX	0,6	4,7	10,3	1,0	2,5	1,1
SE 6 INOX	0,7	5,6	11,7	1,2	2,7	1,3
SE 8 INOX	0,8	7,4	14,7	1,2	3,2	1,5
SE 10 INOX	1,0	11,0	19,0	1,7	3,3	1,8
SE 12 INOX	1,0	11,0	19,0	1,7	3,3	1,8
SE 16 INOX	1,0	14,7	23,8	1,7	3,7	2,2
SE 20 INOX	1,2	18,5	28,4	2,0	4,0	2,6
SE 30 INOX	1,5	27,9	40,5	2,0	5,0	3,5
SE 35 INOX	1,5	32,2	46,8	2,5	5,6	3,9

MATERIAL

stainless steel AISI 420

Hexagonal nuts UNI 5588 (DIN. 934) - UNI 5589 (DIN. 936)

Dimensions mm

D 6H	S	regular thread	fine pitch thread	E		e
				medium acc. UNI 5588	reduced version acc. UNI 5589	
M4	7	4x0,7	-	3,2	2	8,05
M5	8	5x0,8	-	4	2,5	9,20
M6	10	6x1	-	5	4	11,50
M7	11	7x1	-	5,5	4	12,65
M8	13	8x1,25	-	6,5	5	14,95
M10	17	10x1,50		8	6	19,55
M10x1,25	17		10x1,25	8	6	19,55
M12	19	12x1,75		10	7	21,85
M12x1,25	19		12x1,25	10	7	21,85
M14	22	14x2,00		11	8	25,30
M14x1,5	22		14x1,5	11	8	25,30
M16	24	16x2,00		13	8	27,60
M16x1,5	24		16x1,5	13	8	27,60
M18	27	18x2,50		15	9	31,05
M18x1,5	27		18x1,5	15	9	31,05
M20	30	20x2,50		16	9	34,50
M20x1,5	30		20x1,5	16	9	34,50
M22	32	22x2,50		18	10	36,80
M22x1,5	32		22x1,5	18	10	36,80
M24	36	24x3,00		19	10	41,40
M24x2	36		24x2	19	10	41,40
M27	41	27x3,00		22	12	47,15
M27x2	41		27x2	22	12	47,15
M30	46	30x3,50		24	12	52,90
M30x2	46		30x2	24	12	52,90
M33	50	33x3,50		26	14	57,50
M33x2	50		33x2	26	14	57,50
M36	55	36x4,00		29	14	63,25
M36x2	55		36x2	29	14	63,25
M39	60	39x4,00		39	16	69,00
M39x2	60		39x2	39	16	69,00
M42	65	42x4,50		42	16	74,75
M42x2	65		42x2	42	16	74,75
M45	70	45x4,50		45	18	80,50
M45x2	70		45x2	45	18	80,50
M48	75	48x5,00		48	18	86,25
M48x2	75		48x2	48	18	86,25
M52	80	52x5,00		52	20	92,00
M52x3	80		52x3	52	20	92,00
M56	85	56x5,50		56	22	97,75
M56x4	85		56x4	56	22	97,75

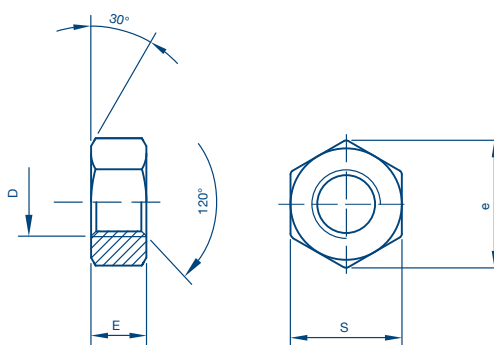

MATERIAL

steel

6S resistance class

(according to UNI 3740 standard)

Surface protection:

- Zinc plating according to standard EN ISO 4042, Fe/Zn 8c...
- Chromate treatment (passivation)
example: type A please add 1A
(ex.: M20 1A)
- Surface treatment table at page 6

HEXAGONAL
NUTS

CLEVIS ACCESSORIES

chiavette unificate

1. PRODUCT DESCRIPTION

Ball joints are mechanical units for the connection of 2 parts which are perpendicular with respect to each other. They enable the transmission of alternating forces through angular and oscillating movements, at a moderate speed.

They are standard products which are produced according to the following standards:

DIN 71802

Ball joints:

a) Form C: without safety clip S and therefore without its external slot and the two holes for the clip itself

b) Form CS: with safety clip S mounted in the slot and the two holes of the housing.

Available with or without nut (mounted or separated)

DIN 71805

Ball Socket

a) Form A: without slot and holes for the safety clip and with the mounted snap ring R

b) Form B: with external slot and holes for the safety clip S and with the internal snap ring R

DIN 71803

Ball Stud

a) Form C: with thread

b) Form B: without thread, to rivet

The ball sockets DIN 71805 produced and supplied by Chiavette Unificate have been improved by the spanner's execution. Upon request, they could be also supplied without spanner surface

All our products could be supplied with electrolytic coatings according to the standards stated at page 6 and/or unfinished.

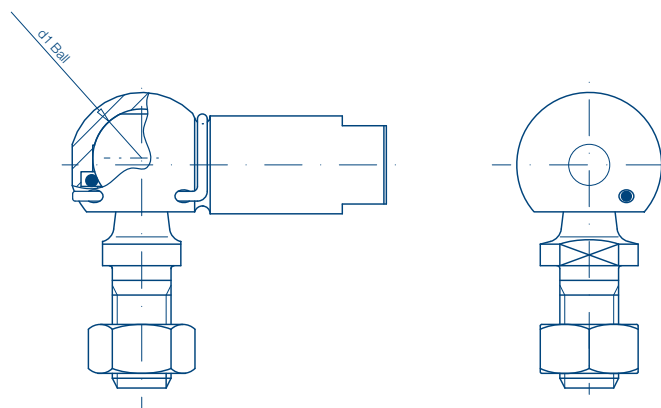

2. TECHNICAL DATA

MATERIALS

Ball stud: carbon steel with 60 daN/mm² resistance to tensile stress and inner ring hardened on the surface with hardness ≥ 52 HRC in alternative (1.4305 - AISI 303)

Ball socket: steel 11SMnPb30 with a 50 daN/mm² resistance to tensile stress (1.0718) in alternative (1.4305 - AISI 303)

Springs: steel for springs C98 UNI EN 10270-1 DH in alternative (1.4319 - AISI 302)

Lubrication: spherical coupling loaded during assembly with LITHIUM grease, NLGI 1 grade

Nuts: see table at page 67

Extraction and Insertion force BALL STUD - BALL SOCKET

The load values requested for the extraction and insertion of the ball stud from/to the ball socket's housing with the mounted "R" spring, with the joint free from grease, are indicated in the following table:

d1 (ball stud inner ring diameter)	8	10	13	16	19
Extraction force [daN] min	3	4	6	8	10
Insertion force [daN] max	20	25	32	35	40

Sliding moment

In the male-female coupling (with grease), the male in a horizontal position falls with a force F applied to the extremity of the male thread (see diagram), according to the table below:

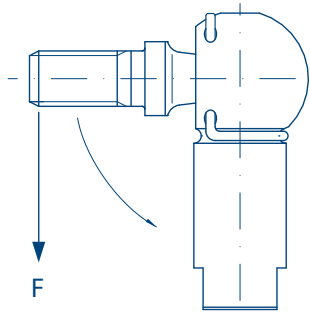

DESIGNATION	max. force (daN)
C 8 M5	0,4
CS 8 M5	0,4
C 10 M6	0,5
CS 10 M6	0,5
C 13 M8	0,6
CS 13 M8	0,6
C 16 M10 - M12	0,7
CS 16 M10 - M12	0,7
C 19 M14 - M16	0,8
CS 19 M14 - M16	0,8

Permissible load and tightening torque

The maximum permissible load for the angular joint is given in the following table; it is also important to tighten the nut as indicated:

DESIGNATION	Permissible load [daN]		Nut tightening torque (daN·m)
	static	dynamic	
C 8 M5	50	20	0,35
CS 8 M5	50	20	0,35
C 10 M6	100	40	0,74
CS 10 M6	100	40	0,74
C 13 M8	200	80	1,80
CS 13 M8	200	80	1,80
C 16 M10	400	160	3,50
CS 16 M10	400	160	3,50
C 16 M12	400	160	4,20
CS 16 M12	400	160	4,20
C 19 M14	800	320	7,00
CS 19 M14	800	320	7,00
C 19 M16	800	320	8,00
CS 19 M16	800	320	8,00

Form
CS

BALL JOINTS

DIN 71802 form CS



Dimensions mm

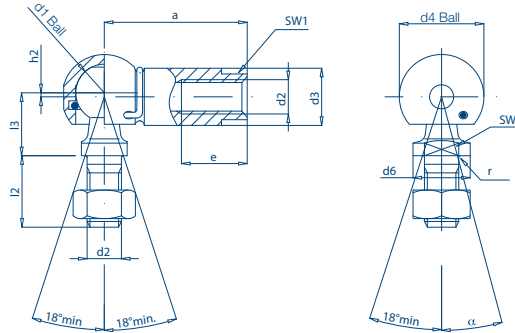

DESIGNATION	d1	d2 6g/6H**	a ±0,3	d3 ±0,5	d4 ±0,5	d6 h14	e min.	h2 ±0,5	l2 ±0,3	l3 ±0,3	r max.	*sw h14	*sw1 h14	α° ≈	weight ≈ (kg)
CS 8 M5	8	M5	22	8	12,8	8	10,2	0,65	10,2	9	0,3	7	7	10	0,015
CS10 M6	10	M6	25	10	14,8	10	11,5	0,7	12,5	11	0,3	8	8	15	0,025
CS13 M8	13	M8	30	13	19,3	13	14	1,15	16,5	13	0,5	11	11	15	0,053
CS16 M10	16	M10	35	16	24	16	15,5	1,15	20	16	0,5	13	13	15	0,104
CS16 M12	16	M12	35	16	24	16	15,5	1,15	20	16	0,5	13	-	15	0,150
CS19 M14x1,5	19	M14x1,5	45	22	30	19	21,5	0,5	28	20	0,8	16	-	15	0,221
CS19 M14x2	19	M14	45	22	30	19	21,5	0,5	28	20	0,8	16	-	15	0,221
CS19 M16	19	M16	45	22	30	19	21,5	0,5	28	20	0,8	16	-	15	0,221

*spanner flats
**tolerances d2: ball stud 6g-threaded hole 6H

Form
C

DIN 71802 form C



Dimensions mm

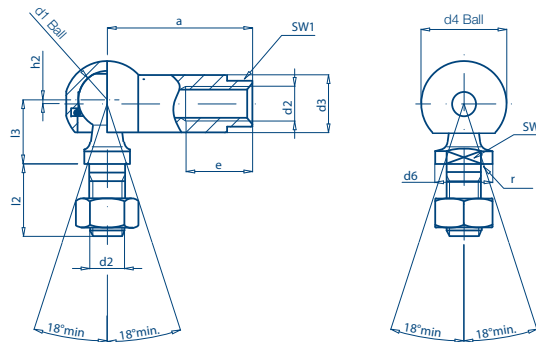

DESIGNATION	d1	d2 6g/6H**	a ±0,3	d3 ±0,5	d4 ±0,5	d6 h14	e min.	h2 ±0,5	l2 ±0,3	l3 ±0,3	r max.	*sw h14	*sw1 h14	weight ≈ (kg)
C 8 M5	8	M5	22	8	12,8	8	10,2	0,65	10,2	9	0,3	7	7	0,015
C10 M6	10	M6	25	10	14,8	10	11,5	0,7	12,5	11	0,3	8	8	0,025
C13 M8	13	M8	30	13	19,3	13	14	1,15	16,5	13	0,5	11	11	0,053
C16 M10	16	M10	35	16	24	16	15,5	1,15	20	16	0,5	13	13	0,104
C16 M12	16	M12	35	16	24	16	15,5	1,15	20	16	0,5	13	-	0,150
C19 M14x1,5	19	M14x1,5	45	22	30	19	21,5	0,5	28	20	0,8	16	-	0,221
C19 M14x2	19	M14	45	22	30	19	21,5	0,5	28	20	0,8	16	-	0,221
C19 M16	19	M16	45	22	30	19	21,5	0,5	28	20	0,8	16	-	0,221

*spanner flats
**tolerances d2: ball stud 6g-threaded hole 6H

For left-hand thread add "LH" (ex. CS 16 M10 LH o C13 M8 LH)
Technical reading from page 68 to page 69

MATERIALS

Ball stud: carbon steel with 60 daN/mm² resistance to tensile stress and inner ring hardened on the surface with a ≥ 52 HRC hardness

Ball socket: steel 11SMnPb30 with a 50 daN/mm² resistance to tensile stress (1.0718)

Internal snap ring "R": steel for springs C98 UNI EN 10270-1 DH

Safety clip "S": steel for springs C98 UNI EN 10270-1 DH

Surface protection:

- Zinc plating according to EN ISO 4042, Fe/Zn 8c...
- Chromate treatment (passivation) example: type A please add 1A (ex.:CS 10 M6 1A)
- Surface treatment table at page 6

Tolerances:

The dimensional tolerances shown in the table make reference to zinc plated products.

Similar to DIN 71802 form CS long version

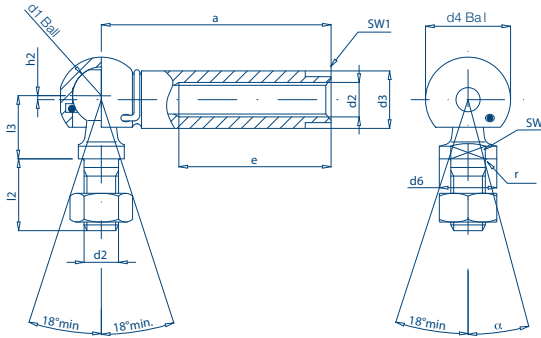

Form
CSL

BALL JOINTS

Dimensions mm

DESIGNATION	d1	d2	a	d3	d4	d6	e	h2	l2	l3	r	*sw	*sw1	α°	weight ≈ (kg)
		6g/6H**	±0,3	±0,5	±0,5	h14	min.	±0,5	±0,3	±0,3	max.	h14	h14	≈	
CSL10 M6x40	10	M6	40	10	14,8	10	26,5	0,7	12,5	11	0,3	8	8	15	0,031
CSL13 M8x45	13	M8	45	13	19,3	13	29	1,15	16,5	13	0,5	11	11	15	0,063
CSL16 M10x45	16	M10	45	16	24	16	30,5	1,15	20	16	0,5	13	13	15	0,113

Similar to DIN 71802 form C long version

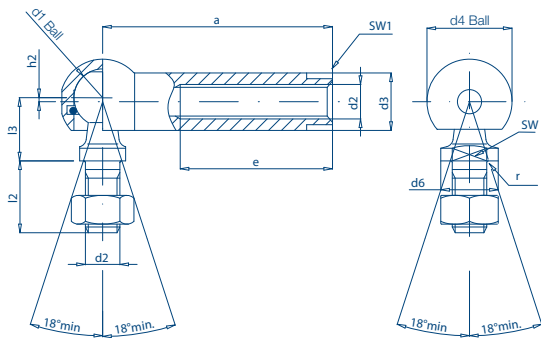

Form
CL

Dimensions mm

DESIGNATION	d1	d2	a	d3	d4	d6	e	h2	l2	l3	r	*sw	*sw1	α°	weight ≈ (kg)
		6g/6H**	±0,3	±0,5	±0,5	h14	min.	±0,5	±0,3	±0,3	max.	h14	h14	≈	
CL10 M6x40	10	M6	40	10	14,8	10	26,5	0,7	12,5	11	0,3	8	8	15	0,031
CL13 M8x45	13	M8	45	13	19,3	13	29	1,15	16,5	13	0,5	11	11	15	0,063
CL16 M10x45	16	M10	45	16	24	16	30,5	1,15	20	16	0,5	13	13	15	0,113

For left-hand thread add "LH" (ex. CSL 16 M10x45 LH o CL13 M8x45 LH)
Technical reading from page 68 to page 69

MATERIALS

Ball stud: carbon steel with traction resistance of 60 daN/mm² and a ball tempered on the surface with hardness ≥ 52 Hrc

Ball socket: 11SMnPb30 steel with tensile strength of 50 daN/mm² (1.0718)

Internal snap ring "R": spring steel C98 UNI EN 10270-1 DH

Safety clip "S": spring steel C98 UNI EN 10270-1 DH

Surface protection:

- Zinc plating according to EN ISO 4042, Fe/Zn 8c...
- Chromate treatment (passivation) example: type A please add 1A (ex.:CS 10 M6 1A)
- Surface treatment table at page 6

Tolerances:

The dimensional tolerances shown in the table make reference to zinc plated products.

Form
CS
INOX

BALL JOINTS
STAINLESS STEEL Version

DIN 71802 form CS

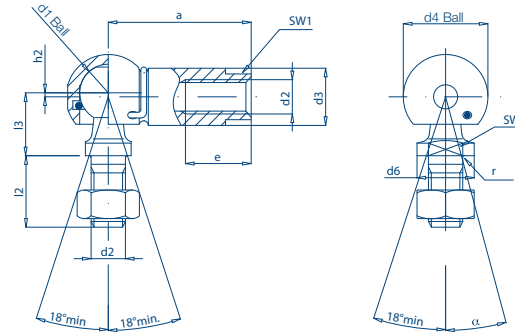

Dimensions mm

DESIGNATION	d1	d2 6g/6H**	a ±0,3	d3 ±0,5	d4 ±0,5	d6 h14	e min.	h2 ±0,5	l2 ±0,3	l3 ±0,3	r max.	*sw h14	*sw1 h14	α° ≈	weight ≈ (kg)
CS 8 M5 INOX	8	M5	22	8	12,8	8	10,2	0,65	10,2	9	0,3	7	7	10	0,015
CS10 M6 INOX	10	M6	25	10	14,8	10	11,5	0,7	12,5	11	0,3	8	8	15	0,025
CS13 M8 INOX	13	M8	30	13	19,3	13	14	1,15	16,5	13	0,5	11	11	15	0,053
CS16 M10 INOX	16	M10	35	16	24	16	15,5	1,15	20	16	0,5	13	13	15	0,104
CS16 M12 INOX	16	M12	35	16	24	16	15,5	1,15	20	16	0,5	13	-	15	0,150
CS19 M14x1,5 INOX	19	M14x1,5	45	22	30	19	21,5	0,5	28	20	0,8	16	-	15	0,221
CS19 M14x2 INOX	19	M14	45	22	30	19	21,5	0,5	28	20	0,8	16	-	15	0,221
CS19 M16 INOX	19	M16	45	22	30	19	21,5	0,5	28	20	0,8	16	-	15	0,221

*spanner flats
**tolerances d2: ball stud 6g-threaded hole 6H

Form
C
INOX

chiavette unificate

DIN 71802 form C

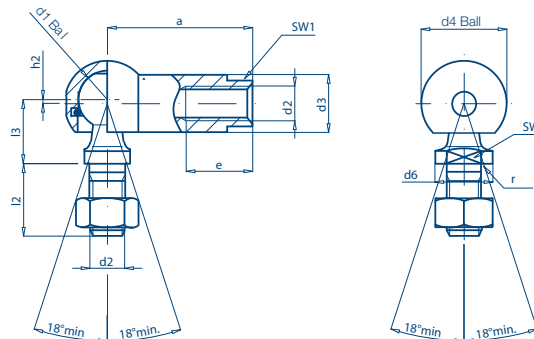

Dimensions mm

DESIGNATION	d1	d2 6g/6H**	a ±0,3	d3 ±0,5	d4 ±0,5	d6 h14	e min.	h2 ±0,5	l2 ±0,3	l3 ±0,3	r max.	*sw h14	*sw1 h14	weight ≈ (kg)
C 8 M5 INOX	8	M5	22	8	12,8	8	10,2	0,65	10,2	9	0,3	7	7	0,015
C10 M6 INOX	10	M6	25	10	14,8	10	11,5	0,7	12,5	11	0,3	8	8	0,025
C13 M8 INOX	13	M8	30	13	19,3	13	14	1,15	16,5	13	0,5	11	11	0,053
C16 M10 INOX	16	M10	35	16	24	16	15,5	1,15	20	16	0,5	13	13	0,104
C16 M12 INOX	16	M12	35	16	24	16	15,5	1,15	20	16	0,5	13	-	0,150
C19 M14x1,5 INOX	19	M14x1,5	45	22	30	19	21,5	0,5	28	20	0,8	16	-	0,221
C19 M14x2 INOX	19	M14	45	22	30	19	21,5	0,5	28	20	0,8	16	-	0,221
C19 M16 INOX	19	M16	45	22	30	19	21,5	0,5	28	20	0,8	16	-	0,221

*spanner flats
**tolerances d2: ball stud 6g-threaded hole 6H

For left-hand thread add "LH" (ex. CS 16 M10 INOX LH)
Technical reading from page 68 to page 69

MATERIAL

Ball stud: stainless steel (1.4305 - AISI 303)

Ball socket: stainless steel (1.4305 - AISI 303)

Internal snap ring "R": stainless steel (1.4319 - AISI 302)

Safety spring "S": (1.4319 - AISI 302)

Similar to DIN 71802 form CS - long version

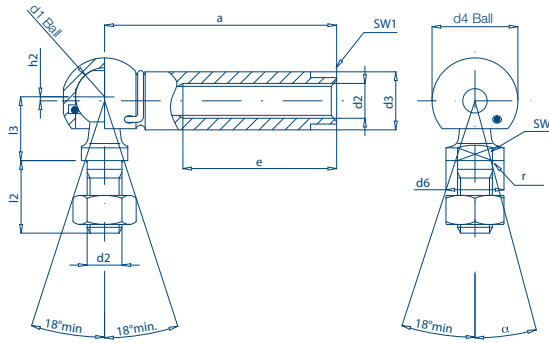

Form
**CSL
INOX**

Dimensions mm

DESIGNATION	d1	d2	a	d3	d4	d6	e	h2	l2	l3	r	*sw	*sw1	α°	weight (kg)
		6g/6H**	$\pm 0,3$	$\pm 0,5$	$\pm 0,5$	h14	min.	$\pm 0,5$	$\pm 0,3$	$\pm 0,3$	max	h14	h14	\approx	\approx
CSL10 M6x40 INOX	10	M6	40	10	14,8	10	26,5	0,7	12,5	11	0,3	8	8	15	0,031
CSL13 M8x45 INOX	13	M8	45	13	19,3	13	29	1,15	16,5	13	0,5	11	11	15	0,063
CSL16 M10x45 INOX	16	M10	45	16	24	16	30,5	1,15	20	16	0,5	13	13	15	0,113

For left-hand thread add "LH" (ex. CSL 16 M10x45 INOX LH)
Technical reading from page 68 to page 69

MATERIAL

Ball stud: stainless steel (1.4305 - AISI 303)

Ball socket: stainless steel (1.4305 - AISI 303)

Internal snap ring "R": stainless steel (1.4319 - AISI 302)

Safety spring "S": stainless steel (1.4319 - AISI 302)

*spanner flats
**tolerances d2: ball stud 6g-threaded hole 6H

BALL JOINTS
STAINLESS STEEL Version

Neoprene sealing cup for ball joints

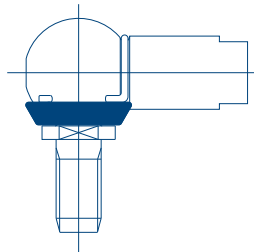
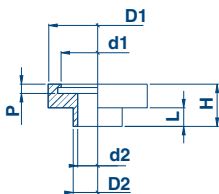

DESIGNATION	\emptyset	D1	d1	D2	d2	H	L	P
NEOPRENE SEALING CUP	8	11,5	9	5,4	4	4,5	1,5	1,5
NEOPRENE SEALING CUP	10	13	10,5	6,9	5,5	6,5	3,5	1,5
NEOPRENE SEALING CUP	13	17	14	8,6	7	7,5	3,5	2
NEOPRENE SEALING CUP	16	21	17,5	10,5	9	8,5	4,5	2
NEOPRENE SEALING CUP	19	25	20	14,5	13	10	6	2

chiavette unificate

Form A

BALL JOINTS

Ball socket DIN 71805 form "A" with internal snap ring

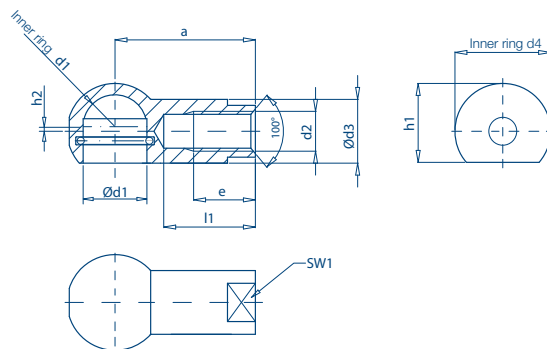

Dimensions mm

DESIGNATION	d1 H9	d2 6H	a ±0,3	d3 ±0,5	d4 ±0,5	e min	l1 max.	h1 ±0,4	h2 ±0,5	*sw1 h14	weight (kg) ≈
A8 M5	8	M5	22	8	12,8	10,2	15	10,8	0,65	7	0,009
A10 M6	10	M6	25	10	14,8	11,5	17	12,3	0,7	8	0,014
A13 M8	13	M8	30	13	19,3	14	20	15,8	1,15	11	0,029
A16 M10	16	M10	35	16	24	15,5	22	20,0	1,15	13	0,057
A16 M12	16	M12	35	16	24	15,5	22	20,0	1,15	-	0,057
A19 M14x1,5	19	M14x1,5	45	22	30	21,5	28	25,0	0,5	-	0,125
A19 M14	19	M14	45	22	30	21,5	28	25,0	0,5	-	0,125
A19 M16	19	M16	45	22	30	21,5	28	25,0	0,5	-	0,125

* spanner flats

Form B

Ball socket DIN 71805 form "B" with internal snap ring

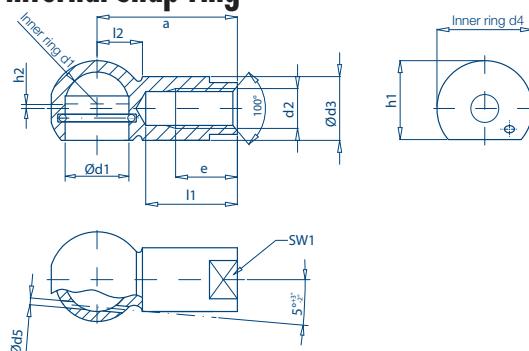

Dimensions mm

DESIGNATION	d1 H9	d2 6H	a ±0,3	d3 ±0,5	d4 ±0,5	d5 ±0,15	e min	l1 max.	h1 ±0,4	h2 ±0,5	l2 ±0,3	*sw1 h14	weight (kg) ≈
B8 M5	8	M5	22	8	12,8	1,3	10,2	15	10,8	0,65	6,3	7	0,009
B10 M6	10	M6	25	10	14,8	1,3	11,5	17	12,3	0,7	7	8	0,014
B13 M8	13	M8	30	13	19,3	1,6	14	20	15,8	1,15	9,1	11	0,029
B16 M10	16	M10	35	16	24	1,8	15,5	22	20,0	1,15	11,4	13	0,057
B16 M12	16	M12	35	16	24	1,8	15,5	22	20,0	1,15	11,4	-	0,057
B19 M14x1,5	19	M14x1,5	45	22	30	1,9	21,5	28	25,0	0,5	12,5	-	0,125
B19 M14	19	M14	45	22	30	1,9	21,5	28	25,0	0,5	12,5	-	0,125
B19 M16	19	M16	45	22	30	1,9	21,5	28	25,0	0,5	12,5	-	0,125

* spanner flats

For left-hand thread add "LH" (ex. A 16 M10 LH)
Technical reading from page 68 to page 69

MATERIAL

Ball socket: steel 11SMnPb30 with a 50 daN/mm² resistance to tensile stress (1.0718)

Internal snap ring "R": steel for springs C98 UNI EN 10270-1 DH

Surface protection:

- Zinc plating according to EN ISO 4042, Fe/Zn 8c...
- Exemple of chromate treatment (passivation): type A add 1A (ex.: B 10 M6 1A)
- Surface treatments table at page 6

Tolerances:

The dimensional tolerances in the table make reference to zinc plated products.

Ball socket similar to DIN 71805 form "A" - long version with internal snap ring

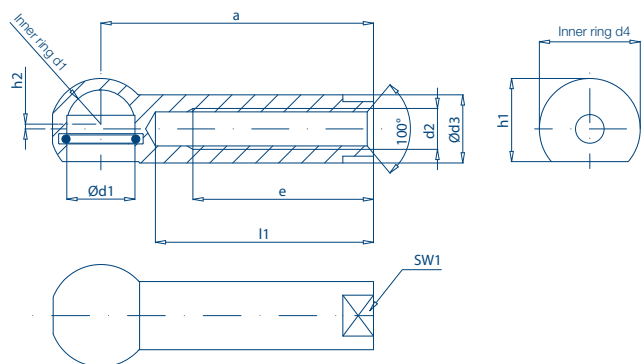

Form
AL

BALL JOINTS

Dimensions mm

DESIGNATION	d1	d2	a	d3	d4	e	l1	h1	h2	*sw1	weight (kg) ≈
	H9	6H	±0,3	±0,5	±0,5	min	max.	±0,4	±0,5	h14	
AL10 M6	10	M6	40	10	14,8	26,5	32	12,3	0,7	8	0,015
AL13 M8	13	M8	45	13	19,3	29	34	15,8	1,15	11	0,039
AL16 M10	16	M10	45	16	24	30,5	35,5	20,0	1,15	13	0,067

*spanner flats

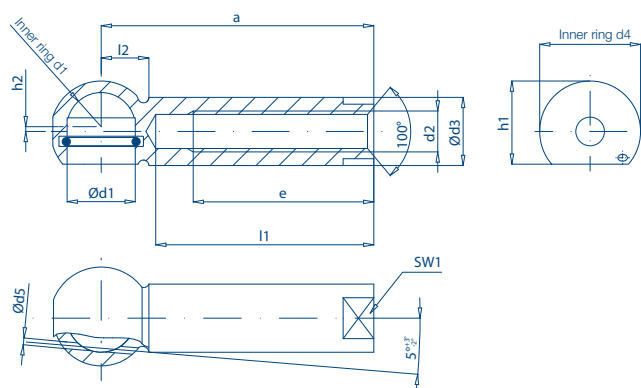

Form
BL

Dimensions mm

DESIGNATION	d1	d2	a	d3	d4	d5	e	l1	h1	h2	l2	*sw1	weight (kg) ≈
	H9	6H	±0,3	±0,5	±0,5	±0,15	min	max.	±0,4	±0,5	±0,3	h14	
BL10 M6	10	M6	40	10	14,8	1,3	26,5	32	12,3	0,7	7	8	0,015
BL13 M8	13	M8	45	13	19,3	1,6	29	34	15,8	1,15	9,1	11	0,039
BL16 M10	16	M10	45	16	24	1,8	30,5	35,5	20,0	1,15	11,4	13	0,067

*spanner flats

For left-hand thread add "LH" (ex. AL 16 M10 LH)
Technical reading from page 68 to page 69

MATERIAL

Socket: 11SMnPb30 steel with tensile strength of 50 daN/mm² (1.0718)

Internal snap ring "R": spring steel C98 UNI EN 10270-1 DH

Surface protection:

- Zinc plating according to EN ISO 4042, Fe/Zn 8c...
- Chromate treatment (passivation) example: type A please add 1A (ex.: BL10 M6 1A)
- Surface treatment table at page 6

Tolerances:

The dimensional tolerances in the table make reference to zinc plated products.

chiavette unificate

Ball socket DIN 71805 form "A" with internal snap ring

Form
A
INOX

BALL JOINTS
STAINLESS STEEL Version

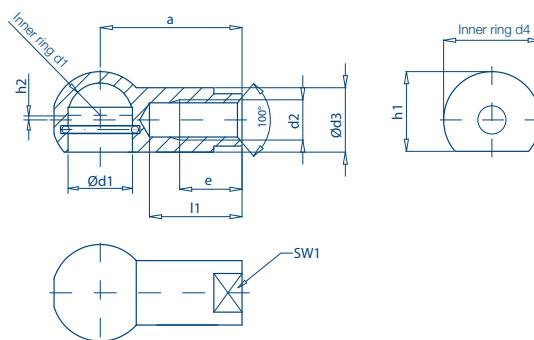

Dimensions mm

DESIGNATION	d1 H9	d2 6H	a ±0,3	d3 ±0,5	d4 ±0,5	e min	l1 max.	h1 ±0,4	h2 ±0,5	*sw1 h14	weight (kg) ≈
A8 M5 INOX	8	M5	22	8	12,8	10,2	15	10,8	0,65	7	0,009
A10 M6 INOX	10	M6	25	10	14,8	11,5	17	12,3	0,7	8	0,014
A13 M8 INOX	13	M8	30	13	19,3	14	20	15,8	1,15	11	0,029
A16 M10 INOX	16	M10	35	16	24	15,5	22	20,0	1,15	13	0,057
A16 M12 INOX	16	M12	35	16	24	15,5	22	20,0	1,15	-	0,057
A19 M14x1,5 INOX	19	M14x1,5	45	22	30	21,5	28	25,0	0,5	-	0,125
A19 M14 INOX	19	M14	45	22	30	21,5	28	25,0	0,5	-	0,125
A19 M16 INOX	19	M16	45	22	30	21,5	28	25,0	0,5	-	0,125

* spanner flats

Ball socket DIN 71805 form "B" with internal snap ring

Form
B
INOX

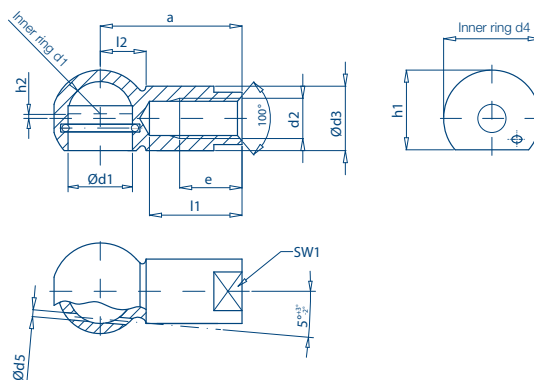

Dimensions mm

DESIGNATION	d1 H9	d2 6H	a ±0,3	d3 ±0,5	d4 ±0,5	d5 ±0,15	e min	l1 max.	h1 ±0,4	h2 ±0,5	l2 ±0,3	*sw1 h14	weight (kg) ≈
B8 M5 INOX	8	M5	22	8	12,8	1,3	10,2	15	10,8	0,65	6,3	7	0,009
B10 M6 INOX	10	M6	25	10	14,8	1,3	11,5	17	12,3	0,7	7	8	0,014
B13 M8 INOX	13	M8	30	13	19,3	1,6	14	20	15,8	1,15	9,1	11	0,029
B16 M10 INOX	16	M10	35	16	24	1,8	15,5	22	20,0	1,15	11,4	13	0,057
B16 M12 INOX	16	M12	35	16	24	1,8	15,5	22	20,0	1,15	11,4	-	0,057
B19 M14x1,5 INOX	19	M14x1,5	45	22	30	1,9	21,5	28	25,0	0,5	12,5	-	0,125
B19 M14 INOX	19	M14	45	22	30	1,9	21,5	28	25,0	0,5	12,5	-	0,125
B19 M16 INOX	19	M16	45	22	30	1,9	21,5	28	25,0	0,5	12,5	-	0,125

* spanner flats

For left-hand thread add "LH" (ex. A 16 M10 INOX LH)
Technical reading from page 68 to page 69

MATERIAL

Socket: stainless steel (1.4305 - AISI 303)

Internal snap ring "R": stainless steel (1.4319 - AISI 302)

Ball socket similar to DIN 71805 form "A" long version with internal snap ring

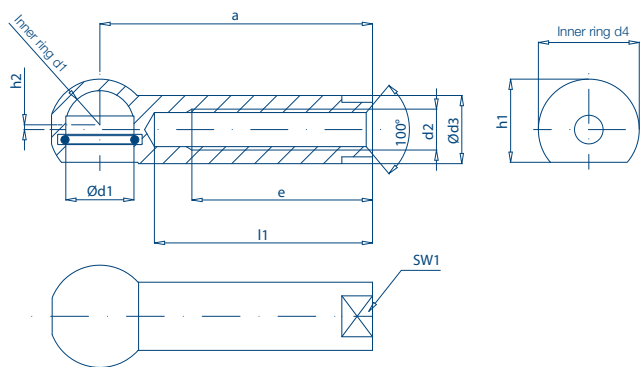

Form
**AL
INOX**

BALL JOINTS
STAINLESS STEEL Version

Dimensions mm

DESIGNATION	d1	d2	a	d3	d4	e	l1	h1	h2	*sw1	weight (kg) ≈
	H9	6H	±0,3	±0,5	±0,5	min	max.	±0,4	±0,5	h14	
AL10 M6 INOX	10	M6	40	10	14,8	26,5	32	12,3	0,7	8	0,015
AL13 M8 INOX	13	M8	45	13	19,3	29	34	15,8	1,15	11	0,039
AL16 M10 INOX	16	M10	45	16	24	30,5	35,5	20,0	1,15	13	0,067

*spanner flats

Ball socket similar to DIN 71805 form "B" long version with internal snap ring

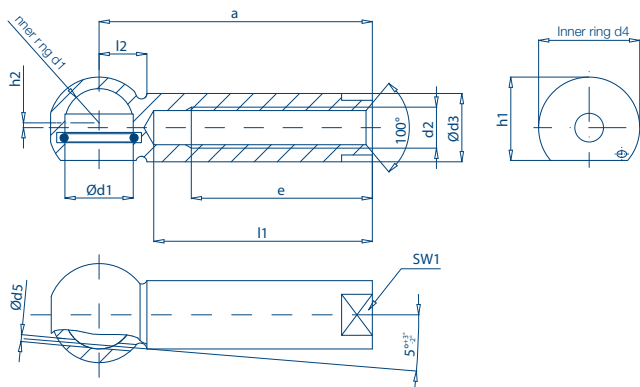

Form
**BL
INOX**

chiavette unificate

Dimensions mm

DESIGNATION	d1	d2	a	d3	d4	d5	e	l1	h1	h2	l2	*sw1	weight (kg) ≈
	H9	6H	±0,3	±0,5	±0,5	±0,15	min	max.	±0,4	±0,5	±0,3	h14	
BL10 M6 INOX	10	M6	40	10	14,8	1,3	26,5	32	12,3	0,7	7	8	0,015
BL13 M8 INOX	13	M8	45	13	19,3	1,6	29	34	15,8	1,15	9,1	11	0,039
BL16 M10 INOX	16	M10	45	16	24	1,8	30,5	35,5	20,0	1,15	11,4	13	0,067

*spanner flats

For left-hand thread add "LH" (ex. AL 16 M10 INOX LH)
Technical reading from page 68 to page 69

MATERIAL

Socket: stainless steel (1.4305 - AISI 303)

Internal snap ring "R": stainless steel (1.4319 - AISI 302)

Ball stud DIN 71803 form C

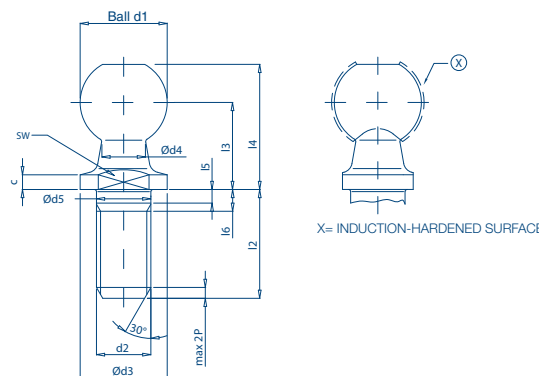

Dimensions mm

DESIGNATION	d1	c	d2	d3	d4	d5	l2	l3	l4	l5	l6	*sw	weight (kg)
	h9	+0,4 0	6g	h14	±0,2	h11	±0,3	±0,3	±0,3	min.	max	h14	≈
C8 M5	8	2	M5	8	4	5	10,2	9	12,5	1,2	4	7	0,005
C10 M6	10	2,2	M6	10	5	6	12,5	11	15,5	1,2	4	8	0,009
C13 M8	13	2,4	M8	13	6,5	8	16,5	13	18,5	1,5	5,3	11	0,018
C16 M10	16	2,7	M10	16	8	10	20	16	23	2,5	7,3	13	0,035
C16 M12	16	2,7	M12	16	8	10	20	16	23	2,5	7,3	13	0,035
C19 M14x1,5	19	3	M14x1,5	19	10	14	28	20	28,5	5,0	10,8	16	0,071
C19 M14	19	3	M14	19	10	14	28	20	28,5	5,0	10,8	16	0,071
C19 M16	19	3	M16	19	10	14	28	20	28,5	5,0	10,8	16	0,071

Ball stud DIN 71803 form B

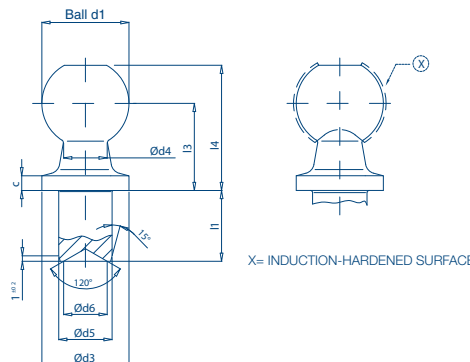

Dimensions mm

DESIGNATION	d1	l1	c	d3	d4	d5	d6	l3	l4	weight (kg)
	h9	±0,2	+0,4 0	h14	±0,2	h11	0 -0,4	±0,3	±0,3	≈
B8x4,0	8	4	2	8	4	5	3	9	12,5	0,0038
B8x7,5	8	7,5	2	8	4	5	3	9	12,5	0,0043
B10x4,5	10	4,5	2,2	10	5	6	4	11	15,5	0,0071
B10x8,0	10	8	2,2	10	5	6	4	11	15,5	0,0078
B13x5,0	13	5	2,4	13	6,5	8	6	13	18,5	0,0142
B13x10	13	10	2,4	13	6,5	8	6	13	18,5	0,0160
B16x6,0	16	6	2,7	16	8	10	8	16	23	0,0235
B16x13	16	13	2,7	16	8	10	8	16	23	0,0296
B19x12	19	12	3	19	10	14	10	20	28,5	0,0562
B19x18	19	18	3	19	10	14	10	20	28,5	0,0637

Technical reading from page 68 to page 69

MATERIAL

Ball stud: carbon steel with a 60 daN/mm² resistance to tensile stress and inner ring hardened on the surface with a ≥ 52 HRC hardness

Surface protection:

- Zinc plating according to EN ISO 4042, Fe/Zn 8c...
- Example of chromate treatment (passivation): type A please add 1A (ex.: C8 M5 1A)
- Surface treatment table at page 6

Tolerances:

The dimensional tolerances in the table make reference to zinc plated products.

Form
C

BALL JOINTS

Form
B

chiavette unificate

Ball stud DIN 71803 form C

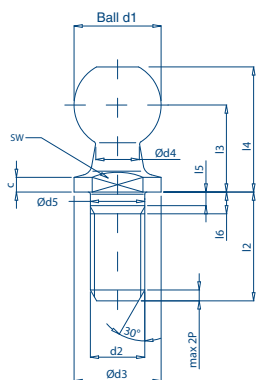

Form
C
INOX

Dimensions mm

DESIGNATION	d1	c +0,4 0	d2 6g	d3 h14	d4 ±0,2	d5 h11	l2 ±0,3	l3 ±0,3	l4 ±0,3	l5 ±0,3	l6 max	*sw h14	weight (kg) ≈
C8 M5 INOX	8	2	M5	8	4	5	10,2	9	12,5	1,2	4	7	0,005
C10 M6 INOX	10	2,2	M6	10	5	6	12,5	11	15,5	1,2	4	8	0,009
C13 M8 INOX	13	2,4	M8	13	6,5	8	16,5	13	18,5	1,5	5,3	11	0,018
C16 M10 INOX	16	2,7	M10	16	8	10	20	16	23	2,5	7,3	13	0,035
C16 M12 INOX	16	2,7	M12	16	8	10	20	16	23	2,5	7,3	13	0,035
C19 M14x1,5 INOX	19	3	M14x1,5	19	10	14	28	20	28,5	5,0	10,8	16	0,071
C19 M14 INOX	19	3	M14	19	10	14	28	20	28,5	5,0	10,8	16	0,071
C19 M16 INOX	19	3	M16	19	10	14	28	20	28,5	5,0	10,8	16	0,071

*spanner flats

Technical reading from page 68 to page 69

BALL JOINTS
STAINLESS STEEL Version

MATERIAL

Ball stud: stainless steel (1.4305 - AISI 303)

Safety clip "S" for ball joints DIN 71805 form CS

Series

S

BALL JOINTS

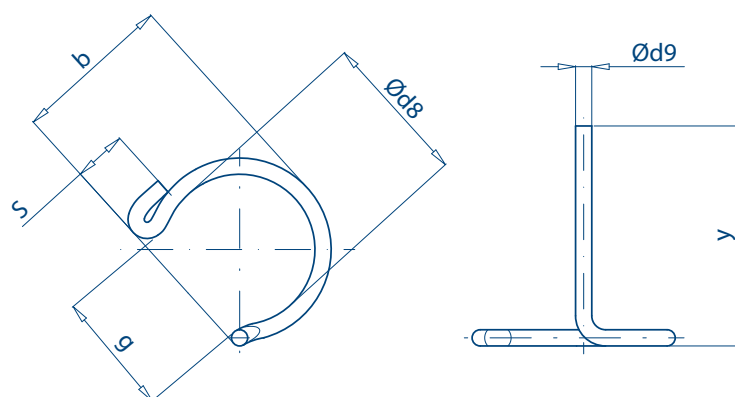

Dimensions mm

DESIGNATION	d8		d9	b ±0,3	g ±0,3	y		S max	weight (kg) 1000 pcs
		Tol.					Tol.		
S8	7	± 0,2	1	8,5	5	12	± 0,3	3,5	0,21
S10	8,7	± 0,2	1	9,5	7,7	12,5	± 0,3	4,2	0,24
S13	11	± 0,2	1,2	12,5	8	15,7	± 0,3	5	0,46
S16	13	± 0,2	1,4	14	11	19	± 0,3	5	0,77
S19	20	± 0,3	1,5	19	16,9	24,4	± 0,4	6	1,10

Technical reading from page 68 to page 69

MATERIAL

steel for springs C98 UNI EN 10270-1 DH in alternative (1.4319 - AISI 302)

Surface protection:

- Zinc plating according to EN ISO 4042, Fe/Zn 8c...
- Example of chromate treatment (passivation): type A please add 1A (ex.: S 10 1A)
- Surface treatment table at page 6

Tolerances:

The dimensional tolerances in the table are referred to zinc plated products.

Axial joints similar to DIN 71802

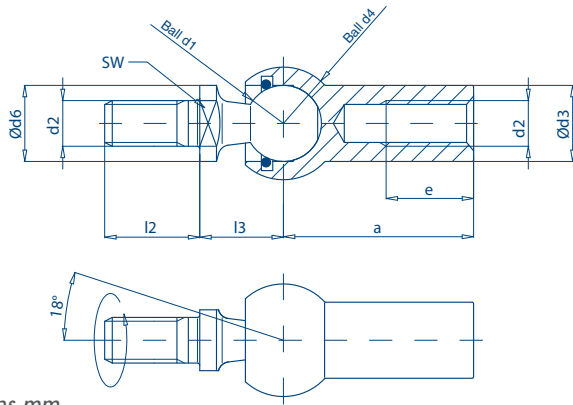

Series
AXA

**tolerances d2: ball stud 6g - f-threaded hole 6H

Dimensions mm

DESIGNATION	d1	d2	a	d3	d4	d6	e	l2	l3	*sw	weight (kg)
	h9	6g/6H**	±0,3	±0,5	±0,5	h14	min.	±0,3	±0,3	h14	~
AXA 8 M5	8	M5	22	8	12,8	8	10,2	10,2	9	7	0,015
AXA10 M6	10	M6	25	10	14,8	10	11,5	12,5	11	8	0,025
AXA13 M8	13	M8	30	13	19,3	13	14	16,5	13	11	0,053
AXA16 M10	16	M10	35	16	24	16	15,5	20	16	13	0,104
AXA16 M12	16	M12	35	16	24	16	15,5	20	16	13	0,150
AXA19 M14x1,5	19	M14x1,5	45	22	30	19	21,5	28	20	16	0,221
AXA19 M14x2	19	M14	45	22	30	19	21,5	28	20	16	0,221
AXA19 M16	19	M16	45	22	30	19	21,5	28	20	16	0,221

For left-hand thread add "LH" (ex. AXA16 M10 LH)
Technical reading from page 68 to page 69

MATERIAL

Ball stud: carbon steel with tensile strength of 60 daN/mm² and a ball tempered on the surface with hardness ≥ 52 HRC stainless steel AISI 303 (1.4305) on request

Ball socket: steel 11SMnPb30 with tensile strength of 50 daN/mm² (1.0718) stainless steel (1.4305 - AISI 303) upon request

Internal snap ring "R": steel for springs C98 UNI EN 10270-1 DH stainless steel (1.4319 - AISI 302) upon request

Surface protection:

- Zinc plating according to EN ISO 4042, Fe/Zn 8c...
- Chromate treatment (passivation) example: type A please add 1A (ex.: AXA 10 M6 1A)
- Surface treatment table at page 6

Tolerances:

The dimensional tolerances in the table make reference to zinc plated products.

Neoprene sealing cup for axial joints "AXA" similar to DIN 71802

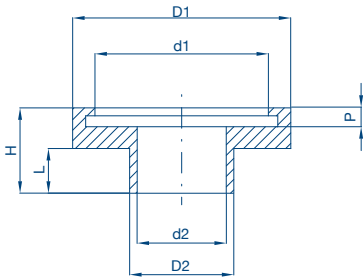

DESIGNATION	Ø	D1	d1	D2	d2	H	L	P
NEOPRENE SEALING CUP	8	11,5	9	5,4	4	4,5	1,5	1,5
NEOPRENE SEALING CUP	10	13	10,5	6,9	5,5	6,5	3,5	1,5
NEOPRENE SEALING CUP	13	17	14	8,6	7	7,5	3,5	2
NEOPRENE SEALING CUP	16	21	17,5	10,5	9	8,5	4,5	2
NEOPRENE SEALING CUP	19	25	20	14,5	13	10	6	2

AXIAL JOINTS AND SEALING CUPS

chiavette unificate

Series
GB

SELF-ALIGNING JOINTS

Self-aligning joints

Characteristics: the self-aligning joint enables the compensation of angular bendings and radial shiftings

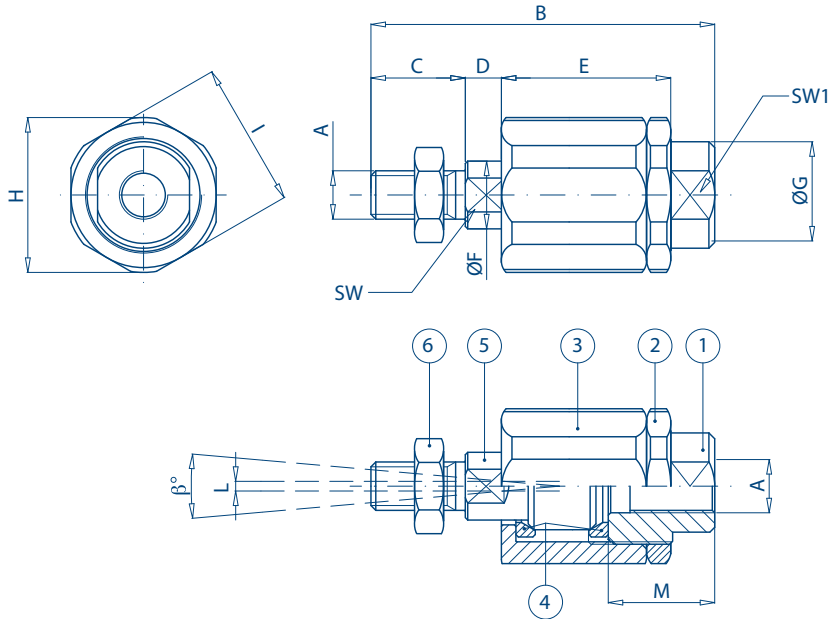

Dimensions mm

DESIGNATION	CYLINDER Ø	A 6g-6H**	B	C	D	E	ØF	ØG	ØH	I	L	M	SW*	β°	SW1*	static load (daN)	weight (kg) (daN)
GB6	12-16	M6x1	35	11	2,5	17,5	6	8,5	14,5	13	1	12,5	5	6°	7	120	0,025
GB8	25-30	M8x1,25	57	21	5	26	8	12,5	19	17	2	16	7	8°	11	250	0,060
GB10x1,25	32	M10x1,25	71,5	20	7,5	35	14	22	32	30	2	22	12	8°	19	500	0,220
GB10	32	M10x1,5	71,5	20	7,5	35	14	22	32	30	2	22	12	8°	19	500	0,220
GB12x1,25	40	M12x1,25	75,5	24	7,5	35	14	22	32	30	2	22	12	8°	19	500	0,230
GB12	40	M12x1,75	75,5	24	7,5	35	14	22	32	30	2	22	12	9°	20	500	0,230
GB16x1,5	50-63	M16x1,5	104	32	10	53	22	32	45	41	2	30	20	6°	27	1000	0,660
GB20x1,5	80-100	M20x1,5	119	40	10	53	22	32	45	41	2	37	20	6°	27	1000	0,700
GB27x2	125	M27x2	147	54	10	60	32	57	70	65	2	48	24	8°	54	3000	2,060
GB36x2	125	M36x2	190	72	15,5	77	39	57	75	70	2	68	32	8°	54	4000	3,110

**tolerances A: ball stud 6g - threaded hole 6H
*spanner flats

POS.	DESIGNATION	MATERIALS	HEAT TREATMENT	SURFACE PROTECTION
1	Cover	11SMnPb30 (1.0718) with R ≥ 50 daN/mm ²		zinc plating according to the standard EN ISO 4042, Fe/Zn 8c 1A
2	Ring nut	11SMnPb30 (1.0718) with R ≥ 50 daN/mm ²		zinc plating according to the standard EN ISO 4042, Fe/Zn 8c 1A
3	Body	11SMnPb30 (1.0718) R ≥ 50 daN/mm ²		zinc plating according to the standard EN ISO 4042, Fe/Zn 8c 1A
4	Housing	39NiCrMo3 (1.6511) hardened and tempered R 100÷120 daN/mm ²	Nitriding HV 0,1 > 600	
5	Pin	39NiCrMo3 (1.6511) hardened and tempered R 100÷120 daN/mm ²	Nitriding HV 0,1 > 600	blackened
6	Nut	Nut UNI 5589-6S see page 67		zinc plating according to the standard EN ISO 4042, Fe/Zn 8c 1A

PRODUCT DESCRIPTION AND TECH. DATA

Feather keys according to DIN 6885- UNI 6604 (former ISO 773)

Feather keys are normally used to transmit the torque from the shaft to the hub

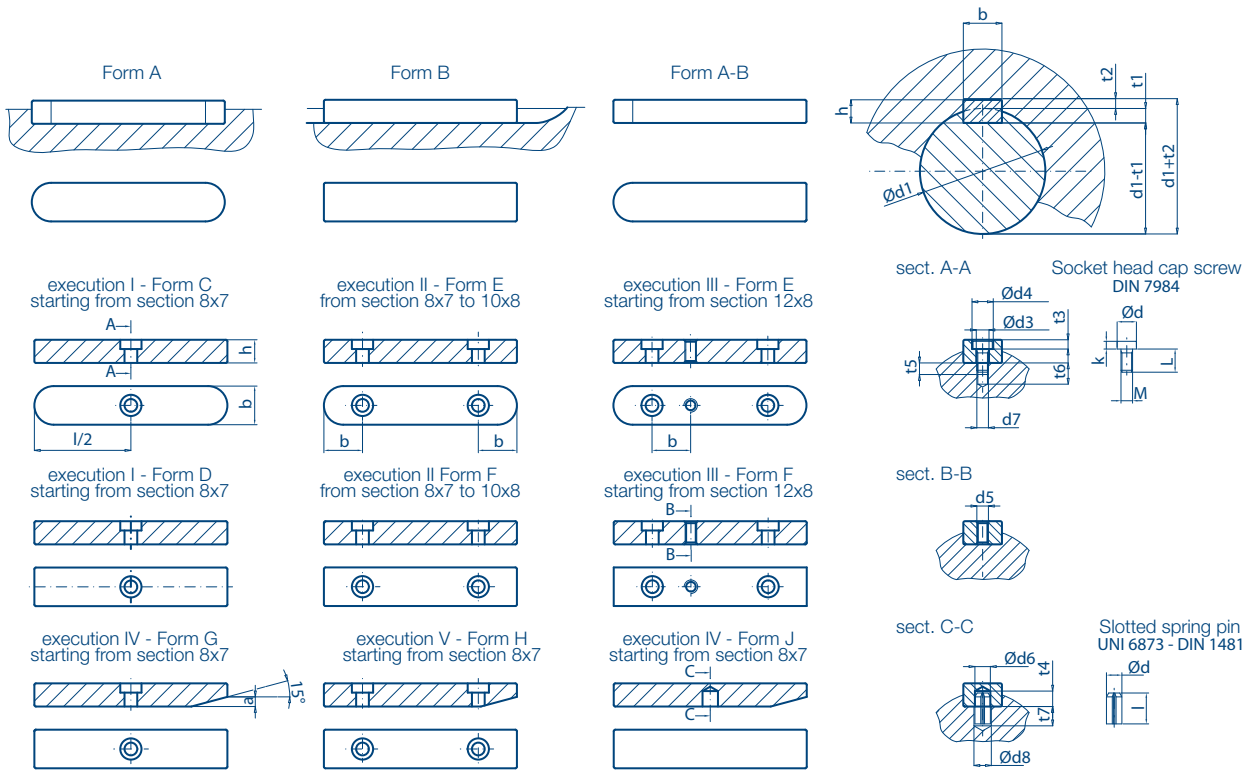

Nomenclature according to the standard:			DESCRIPTION
UNI 6604	UNI 6605	DIN 6885	
Form A		Form A	rounded ends
Form B		Form B	flat ends
	Execution I	Form C	From section 8x7 form A supplied with hole for retaining screw
		Form D	From section 8x7 form B supplied with hole for retaining screw
	Execution II	Form E	From section 8x7 to 10x8 form A supplied with 2 holes for retaining screws
		Form F	From section 8x7 to 10x8 form B supplied with 2 holes for retaining screws
	Execution III	Form E	From section 12x8 form A supplied with 2 holes for retaining screws and 1 threaded hole for the extracting screw
		Form F	From section 12x8 form B supplied with 2 holes for retaining screws and 1 threaded hole for the extracting screw
	Execution IV	Form G	From section 8x7 form B supplied with hole for retaining screw and chamfer
	Execution V	Form H	From section 8x7 form B supplied with 2 holes for retaining screw and chamfer
	Execution VI	Form J	From section 8x7 form B supplied with chamfer and hole for 1 spring dewel sleeve
Form A/B: not included in the standard			if needed the forms A and B can be combined, so that 1 end will be flat and the other one will be rounded

MATERIAL

C45 (1.1191) steel with $R_{\geq 59}$ daN/mm² cold formed according to EN ISO 683-1 : 2018
 stainless steel (1.4401 - AISI 316) with $R_{\geq 59}$ daN/mm² - cold formed 39NiCrMo3 (1.6511) available upon request up to size 20x12 mm and 18NiCrMo5 (1.5919) up to size 12x8 mm.

The relationship between the diameter of the shaft and the section of the key indicated in the dimensional tables refers to normal uses

The use of keys with smaller sections is possible if their resistance is sufficient for the force to be transmitted

The use of keys with larger sections is not recommended.

Tolerances Table for feather keys and keyways

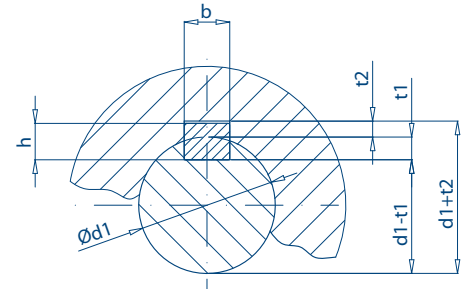

Dimensions mm

FEATHER KEYS

Range		Feather key Section			keyway											
Shaft diameter d		Nominal Dimensions b x h		Tolerances on b ^{h9} h*		Nominal Dimensions b	Width						Depth			
							Tolerances on b						Shaft		Hub	
							For shaft			For hub			t1		t2	
from up to							H9	N9	P9	D10	Js9	P9	Nom.	Tol.	Nom.	Tol.
from up to	6 8	2 x 2	0	0	2	+0,025 0	0 -0,004	-0,006 -0,031	+0,060 +0,020	±0,012	-0,006 -0,031	1,2		1		
from up to	8 10	3 x 3	-0,025	-0,025	3							1,8		1,4		
from up to	10 12	4 x 4			4							2,5		1,8		
from up to	12 17	5 x 5			5							3		2,3		
from up to	17 22	6 x 4	0 -0,030	0	6	+0,030 0	0 -0,030	-0,012 -0,042	+0,078 +0,030	±0,015	-0,012 -0,042	2,5	+0,1 0	1,8	+0,1 0	
		6 x 5		0 -0,030	6							3		2,3		
		6 x 6			6							3,5		3,5		
from up to	22 30	8 x 5			8							3		2,3		
		8 x 6			8							3,5		2,8		
		8 x 7	0 -0,090	0	8	+0,036 0	0 -0,036	-0,015 -0,051	+0,098 +0,040	±0,018	-0,015 -0,051	4		3,3		
		8 x 8	0 -0,036	0	8							5		3,3		
from up to	30 38	10 x 8	0 -0,090	0	10							5		3,3		
		10 x 10	0 -0,036	0	10							6		4,3		
from up to	38 44	12 x 8	0 -0,090	0	12							5		3,3		
		12 x 12	0 -0,043	0	12							7,5		4,9		
from up to	44 50	14 x 9	0 -0,090	0	14	+0,043 0	0 -0,043	-0,018 -0,061	+0,120 +0,050	±0,021	-0,018 -0,061	5,5	+0,2 0	3,8	+0,2 0	
		14 x 14	0 -0,043	0	14							9		5,4		
from up to	50 58	16 x 10	0 -0,090	0	16							6		4,3		
from up to	58 60	18 x 11	0 -0,110	0	18							7		4,4		
from up to	65 75	20 x 12			20							7,5		4,9		
from up to	75 85	22 x 14	0 -0,052	0	22	+0,052 0	0 -0,052	-0,022 -0,074	+0,149 +0,065	±0,026	-0,022 -0,074	9		5,4		
from up to	85 95	25 x 14		0 -0,110	25							9		5,4		
from up to	95 110	28 x 16			28							10		6,4		
from up to	110 130	32 x 18			32							11		7,4		
from up to	130 150	36 x 20			36							12		8,4		
from up to	150 170	40 x 22	0 -0,062	0	40	0,062 0	0 -0,062	-0,026 -0,088	+0,180 +0,080	±0,031	-0,026 -0,088	13		9,4		
from up to	170 200	45 x 25		0 -0,130	45							15		10,4		
from up to	200 230	50 x 28			50							17		11,4		
from up to	230 260	56 x 32			56							20	+0,3 0	12,4	+0,3 0	
from up to	260 290	63 x 32	0 -0,074	0	63	+0,074 0	0 -0,074	-0,032 -0,106	+0,220 +0,100	±0,037	-0,032 -0,106	20		12,4		
from up to	290 330	70 x 36		0 -0,160	70							22		14,4		
from up to	330 380	80 x 40			80							25		15,4		
from up to	380 440	90 x 45	0 -0,087	0	90	+0,087 0	0 -0,080	-0,037 -0,124	+0,260 +0,120	±0,043	-0,037 -0,124	28		17,4		
from up to	440 500	100 x 50			100							31		19,5		

* the deviation values are referred to the tolerances h9 for square sections and h11 for rectangular sections

Feather keys executions

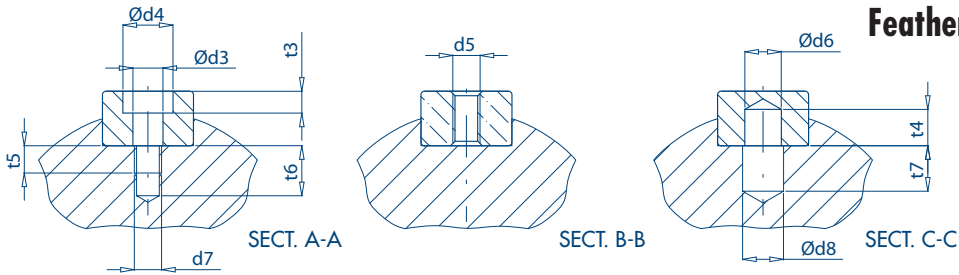

Feather key Section		Sect. A-A							Sect. B-B	Sect. C-C				Slotted spring pin	
Nominal Dimensions bxh	Minimum length of application L	a*	Ød3	Ød4	d7	t3	t5	t6	d5	Ød6 H12	Ød8	t4	t7	Socket head cap screw Thread	diameter
2 x 2															
3 x 3															
4 x 4															
5 x 5															
6 x 4															
6 x 5															
6 x 6															
8 x 5															
8 x 6															
sizes in which is not possible to apply C - D - E - F - G - H - J forms															
8 x 7	40	3	3,4	6	M3	2,4	4	7	M3	4	4,5	4	5	4 x 8	M3 x 8
8 x 8															
10 x 8	50	3	3,4	6	M3	2,4	5	8	M3	4	4,5	4	5	4 x 8	M3 x 10
10 x 10															
12 x 8	56	3	4,5	8	M4	3,2	6	10	M4	5	5,5	5	7	5 x 10	M4 x 10
12 x 12															
14 x 9	63	3,5	5,5	10	M5	4,1	6	10	M5	6	6,5	6	8	6 x 12	M5 x 10
14 x 14															
16 x 10	70	4	5,5	10	M5	4,1	6	10	M5	6	6,5	6	8	6 x 12	M5 x 10
18 x 11	80	4,5	6,6	11	M6	4,8	6	11	M6	8	9	7	11	8 x 16	M6 x 12
20 x 12	90	5	6,6	11	M6	4,8	6	11	M6	8	9	8	10	8 x 16	M6 x 12
22 x 14	100	5,5	6,6	11	M6	4,8	8	13	M6	8	9	8	10	8 x 16	M6 x 12
25 x 14	100	5,5	9	14	M8	6	9	15	M8	10	11	10	12	10 x 20	M8 x 16
28 x 16	110	6,5	11	18	M10	7,3	9	16	M10	12	13	10	18	12 x 24	M10 x 16
32 x 18	110	7	11	18	M10	7,3	10	17	M10	12	13	12	16	12 x 24	M10 x 20
36 x 20	125	8	14	20	M12	8,3	12	20	M12	16	17	14	20	16 x 30	M12 x 25
40 x 22	125	9	14	20	M12	8,3	12	20	M12	16	17	16	18	16 x 30	M12 x 25
45 x 25	125	10	14	20	M12	8,3	15	22	M12	16	17	16	18	16 x 30	M12 x 30
50 x 28	140	11	14	20	M12	8,3	12	19	M12	16	17	16	18	16 x 32	M12 x 30
56 x 32	160	13	14	20	M12	8,3	13	20	M12	16	17	16	18	16 x 32	M12 x 35
63 x 32	180	13	14	20	M12	8,3	13	20	M12	16	17	16	18	16 x 32	M12 x 35
70 x 36	200	14	18	26	M16	11,5	17	24	M16	20	21	20	24	20 x 40	M16 x 40
80 x 40	220	16	18	26	M16	11,5	18	25	M16	20	21	20	24	20 x 40	M16 x 45
90 x 45	250	18	22	33	M20	13,5	20	28	M20	25	26	25	30	25 x 50	M20 x 50
100 x 50	280	20	22	33	M20	13,5	20	28	M20	25	26	25	30	25 x 50	M20 x 50

* execution Form G-H-J

Feather keys standard lengths DIN 6885-UNI 6604 (former ISO 773)



FEATHER KEYS

bxh (mm)	length L (mm)															
	feather keys length tolerance: up to 28 mm from 0 to -0,20 mm, over 28 up to 80 mm from 0 to -0,30 mm, over 80 mm from 0 to -0,50 mm keyway tolerance: up to 28 mm from +0,20 to 0 mm, over 28 up to 80 mm from +0,30 to 0, over 80 mm from +0,50 to 0 mm															
3x3	8	10	12	14	15	16	18	20	22	25	28	30	32	35	36	40
Kg/100 pcs	0,05	0,07	0,08	0,09	0,11	0,11	0,12	0,14	0,15	0,17	0,19	0,21	0,22	0,24	0,25	0,28
4x4	8	10	12	14	15	16	18	20	22	25	28	30	32	35	36	40
Kg/100 pcs	0,09	0,12	0,14	0,17	0,18	0,19	0,22	0,24	0,27	0,30	0,34	0,37	0,39	0,43	0,44	0,49
5x5	8	10	12	14	15	16	18	20	22	25	28	30	32	35	36	40
Kg/100 pcs	0,14	0,17	0,21	0,25	0,27	0,29	0,33	0,37	0,41	0,47	0,53	0,57	0,61	0,66	0,69	0,76
6x4	10	12	14	15	16	18	20	22	25	28	30	32	35	36	40	45
Kg/100 pcs	0,17	0,20	0,24	0,26	0,28	0,31	0,35	0,38	0,43	0,49	0,52	0,56	0,61	0,62	0,69	0,78
6x5	10	12	14	15	16	18	20	22	25	28	30	32	35	36	40	45
Kg/100 pcs	0,21	0,26	0,30	0,33	0,35	0,39	0,43	0,48	0,54	0,61	0,65	0,69	0,76	0,78	0,87	0,98
6x6	10	12	14	15	16	18	20	22	25	28	30	32	35	36	40	45
Kg/100 pcs	0,26	0,31	0,36	0,39	0,42	0,47	0,52	0,59	0,67	0,76	0,80	0,80	0,96	0,98	1,09	1,23
8x5	12	14	15	16	18	20	22	25	28	30	32	35	36	40	45	50
Kg/100 pcs	0,34	0,40	0,43	0,46	0,51	0,57	0,63	0,71	0,80	0,85	0,91	1,00	1,03	1,14	1,28	1,42
8x6	12	14	15	16	18	20	22	25	28	30	32	35	36	40	45	50
Kg/100 pcs	0,41	0,48	0,51	0,55	0,62	0,68	0,75	0,85	0,96	1,03	1,09	1,20	1,23	1,37	1,54	1,71
8x7	12	14	15	16	18	20	22	25	28	30	32	35	36	40	45	50
Kg/100 pcs	0,48	0,56	0,60	0,64	0,72	0,81	0,89	1,03	1,16	1,24	1,34	1,45	1,51	1,69	1,91	2,13
8x8	15	16	18	20	22	25	28	30	32	35	36	40	45	50	55	56
Kg/100 pcs	0,68	0,72	0,81	0,91	1,00	1,13	1,27	1,36	1,45	1,58	1,63	1,81	2,04	2,26	2,49	2,53
10x8	15	16	18	20	22	25	28	30	32	35	36	40	45	50	55	56
Kg/100 pcs	0,85	0,91	1,02	1,13	1,25	1,44	1,63	1,76	1,88	2,07	2,13	2,38	2,70	3,01	3,32	3,39
10x10	15	20	22	25	28	30	32	35	36	40	45	50	55	56	60	63
Kg/100 pcs	1,06	1,41	1,56	1,77	1,98	2,12	2,26	2,47	2,55	2,83	3,18	3,53	3,89	3,96	4,24	4,45
12x8	15	20	22	25	28	30	32	35	36	40	45	50	55	56	60	63
Kg/100 pcs	1,03	1,37	1,51	1,71	1,92	2,08	2,22	2,45	2,52	2,82	3,20	3,58	3,95	4,03	4,34	4,56
12x12	20	22	25	28	30	32	35	36	40	45	50	55	56	60	63	65
Kg/100 pcs	2,05	2,26	2,57	2,87	3,08	3,28	3,59	3,69	4,10	4,62	5,13	5,64	5,75	6,16	6,46	6,67
14x9	20	22	25	28	30	32	35	36	40	45	50	55	56	60	63	65
Kg/100 pcs	1,81	1,99	2,27	2,54	2,72	2,90	3,17	3,26	3,66	4,15	4,65	5,06	5,24	5,62	5,93	6,15
14x14	30	35	40	45	50	55	56	60	63	65	70	80	85	90	100	110
Kg/100 pcs	4,23	4,93	5,64	6,34	7,05	7,75	7,90	8,46	8,88	9,16	9,87	11,28	11,98	12,69	14,10	15,51
16x10	30	35*	40	45	50	55	56	60	63	65	70	80	85	90	100	110
Kg/100 pcs	3,43	4,00	4,57	5,22	5,85	6,43	6,60	7,07	7,77	8,37	9,57	10,27	10,87	12,17	13,37	13,80
18x11	30	40	45	50	55	56	60	63	65	70	75	80	90	100	110	120
Kg/100 pcs	4,30	5,74	6,45	7,17	7,88	8,10	8,65	9,19	9,56	10,30	11,06	11,80	13,40	14,90	16,50	17,80
20x12	40	45	50	55	56	60	63	70	80	90	100	110	120	125	130	140
Kg/100 pcs	6,80	7,65	8,50	9,62	9,79	10,30	11,09	12,39	14,29	16,19	17,99	19,89	21,50	22,69	23,20	25,59
22x14	50	55	60	63	70	80	90	100	110	120	125	130	140	150*	160	180
Kg/100 pcs	10,83	11,92	13,00	14,06	15,76	18,16	20,66	23,06	25,46	27,60	29,06	30,00	32,66	34,50	37,56	42,36
24x14	60	63	70	80	90	100	110	120	125	130	140	150	160	180	200	220
Kg/100 pcs	14,40	15,10	17,00	19,50	22,50	24,80	27,40	30,00	31,50	32,80	35,20	38,00	40,50	48,00	51,00	55,00
25x14	60	63	70	80	90	100	110	120	125	130	140	150	160	180	200	220
Kg/100 pcs	13,90	15,60	17,70	20,50	23,20	26,00	28,70	31,00	32,80	34,00	37,00	39,30	42,50	48,00	53,50	58,90
28x16	55	60	70	80	90	100	110	120	125	130	140	145	150	160	180	200
Kg/100 pcs	17,40	19,00	22,20	26,00	29,60	33,10	36,60	39,50	41,90	43,50	47,10	50,30	54,20	61,20	68,20	75,30
32x18	65	70	80	90	100	110	120	125	130	140	150	160	170	180	200	220
Kg/100 pcs	27,20	29,20	33,40	37,60	42,10	47,60	49,50	53,40	55,50	60,20	64,00	69,20	73,90	78,30	87,30	96,40
36x20	80	90	100	110	120	125	130	140	150	160	170	180	200	220	250	280
Kg/100 pcs	41,30	46,50	52,10	57,80	63,00	68,50	74,70	79,80	86,00	92,20	97,60	108,60	119,60	136,60	153,60	164,50
40x22	70	90	100	110	120	125	130	140	150	160	180	200	220	240	250	280
Kg/100 pcs	43,79	56,30	62,80	70,10	76,30	80,40	83,00	90,80	96,60	105,10	118,10	132,10	146,10	160,40	167,10	187,10
45x25	100	110	120	125	130	140	150	160	180	200	220	240	245	250	260	280
Kg/100 pcs	80,00	88,00	96,50	101,50	105,00	115,50	122,00	132,50	150,50	168,50	185,50	202,30	206,60	212,50	219,20	238,50
50x28																
56x 32																
63x 32																
70x 36	available upon request															
80x 40																
90x 45																
100x 50																

Note: the weight is referred to Form A (mass volume 7,85 kg/mm³)
 Sizes in inches upon request Technical reading from page 83 to page 85

chiavette unificate



Dimensional tolerances for woodruff keys according to ISO 3912-DIN 6888- UNI 6606 standards

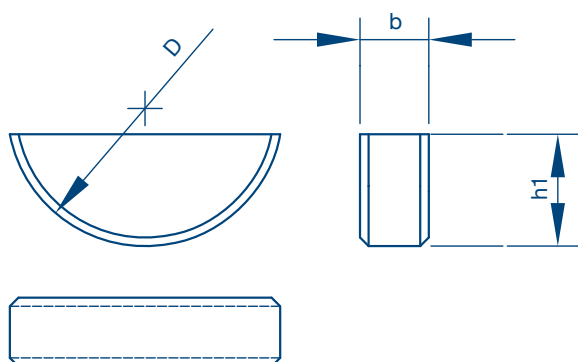

Dimensions mm

Shaft diameter d				standard keys bxhxD or equivalent form	key							
torque transmission		for positioning			Base b		height h ₁		Diameter D		chamfer/radius	
≥	≤	≥	≤		nom.	tol. h ₉	nom.	Tol. h ₁₁	nom.	tol. h ₁₂	min.	max.
3	4	3	4	1,0x1,4x 4	1,0	0 -0,025	1,4	0 -0,060	4	0 -0,120	0,16	0,25
4	5	4	6	1,5x2,6x7	1,5		2,6		7	0 -0,150		
5	6	6	8	2x2,6x7	2,0		3,7	0 -0,075	10	0 -0,180		
6	7	8	10	2x3,7x10	2,5				5,0			
7	8	10	12	2,5x3,7x10	3,0		6,5	0 -0,090	16	0 -0,210		
8	10	12	15	3x5x13	4,0				7,5			
10	12	15	18	3x6,5x16	5,0	6,5	0 -0,090	16	0 -0,210	0,25	0,40	
12	14	18	20	4x6,5x16				7,5				19
14	16	20	22	4x7,5x19	6,0	9,0	0 -0,110	22	0 -0,210			
16	18	22	25	5x6,5x16				10,0		25		
18	20	25	28	5x7,5x19	8,0	11,0	0 -0,110	28	0 -0,210	0,4	0,6	
20	22	28	32	5x9,0x22				10,0				32
22	25	32	36	6x9,0x22	10,0	13,0	0 -0,036	25	0 -0,210			
25	28	36	40	6x10x25				8,0		11,0		
28	32	40	-	8x11x28	10,0	13,0	0 -0,110	32	0 -0,210	0,4	0,6	

For no standard dimension keys, the referred tolerances remain the same

MATERIAL

steel C45 (1.1191) with $R_z \geq 59 \text{ daN/mm}^2$ cold drawn EN ISO 683-1 : 2018 norm

The relation between the shaft diameter and the key section, indicated in the dimensional tables, is referred to the standard use

It is possible to use smaller keys sections, if their resistance is enough for the torque to be transmitted

The use of keys with bigger sections is not recommended

Dimensional tolerances of the keyway for the woodruff keys according to ISO 3912 DIN 6888 UNI 6606

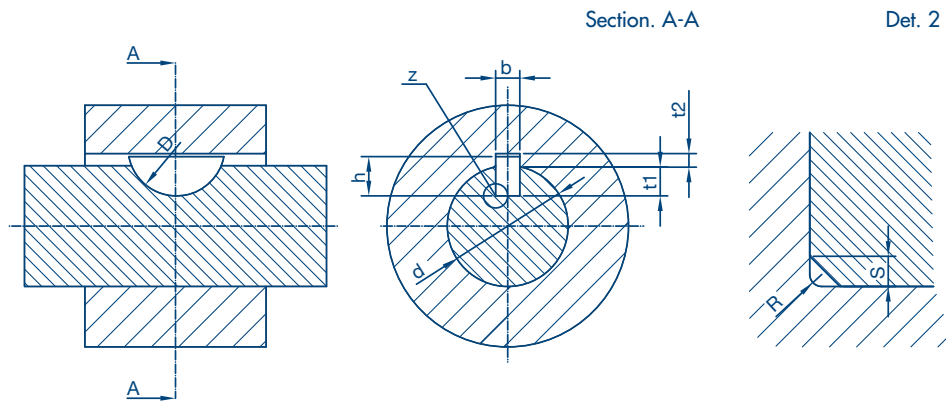

Dimensions mm

Shaft diameter d				standard keys b x h x D or equivalent	nom.	keyway								
transmiss. torque		For positioning				Base b			Depth				Radius R	
≧	≦	≧	≦			type of coupling			shaft		hub			
						normal fit	close fit		t1		t2		max.	min.
						shaft	hub	shaft/hub	nom.	tol.	nom.	tol.		
				Tol. N9	Tol. Js9	Tol. P9	nom.	tol.	nom.	tol.				
3	4	3	4	1,0x1,4x 4	1,0	-0,004 -0,029	±0,012	-0,006 -0,031	1	+0,1 0	0,6	0,16	0,08	
4	5	4	6	1,5x2,6x7	1,5				2		0,8			
5	6	6	8	2x2,6x7	2,0				1,8		1			
6	7	8	10	2x3,7x10					2,9		1,2			
7	8	10	12	2,5x3,7x10	2,5				2,7		1,2			
8	10	12	15	3x5x13	3,0				3,8	1,4	+0,1 0			
10	12	15	18	3x6,5x16					5,3	1,8				
12	14	18	20	4x6,5x16	4,0	0	±0,015	-0,012 -0,042	5	+0,2 0	2,3	0,25	0,16	
14	16	20	22	4x7,5x19					6		1,8			
16	18	22	25	5x6,5x16	5,0	0	±0,015	-0,012 -0,042	4,5	+0,3 0	2,8	0,40	0,25	
18	20	25	28	5x7,5x19					5,5		2,3			
20	22	28	32	5x9,0x22					7		2,8			
22	25	32	36	6x9,0x22	6,0	0	±0,018	-0,015 -0,051	6,5	+0,2 0	3,3	0,40	0,25	
25	28	36	40	6x10x25					7,5		2,8			
28	32	40	-	8x11x28	8,0	0	±0,018	-0,015	8	3,3	3,3	0,40	0,25	
32	38	-	-	10x13x32	10,0	-0,036	±0,018	-0,015	8	3,3	3,3	0,40	0,25	

For no standard dimension keys, the tolerances remain the same

WOODRUFF KEYS ISO 3912 - UNI 6606 - DIN 6888

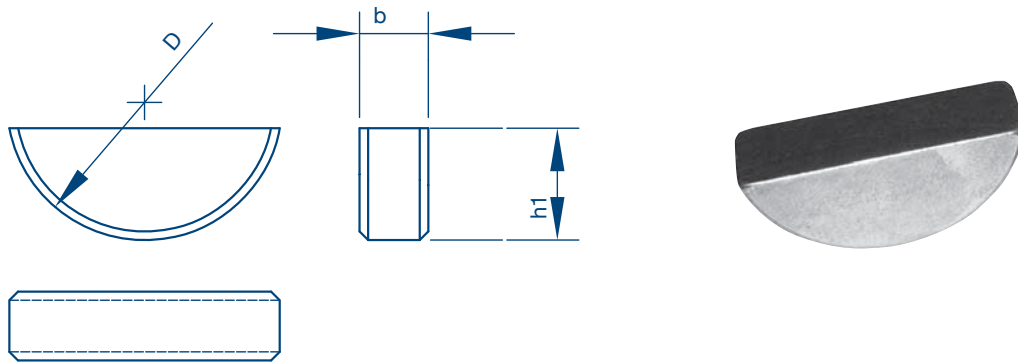

DESIGNATION	b h9	h1 h11	L	D h12	weight [kg/100 pcs]
KEY 1,5X2,6	1,5	2,6	6,76	7	0,012
KEY 2X2,6	2,0	2,6	6,76	7	0,017
KEY 2X3,7	2,0	3,7	9,66	10	0,034
KEY 2,5X3,7	2,5	3,7	9,66	10	0,047
KEY 3X3,7	3,0	3,7	9,66	10	0,060
KEY 2X5	2,0	5,0	12,65	13	0,070
KEY 3X5	3,0	5,0	12,65	13	0,108
KEY 4X5	4,0	5,0	12,65	13	0,141
KEY 3X6,5	3,0	6,5	15,72	16	0,171
KEY 4X6,5	4,0	6,5	15,72	16	0,231
KEY 5X6,5	5,0	6,5	15,72	16	0,290
KEY 3X7,5	3,0	7,5	18,57	19	0,234
KEY 4X7,5	4,0	7,5	18,57	19	0,308
KEY 5X7,5	5,0	7,5	18,57	19	0,397
KEY 4X9	4,0	9,0	21,63	22	0,442
KEY 5X9	5,0	9,0	21,63	22	0,556
KEY 6X9	6,0	9,0	21,63	22	0,556
KEY 5X10	5,0	10,0	24,49	25	0,704
KEY 6X10	6,0	10,0	24,49	25	0,837
KEY 6X11	6,0	11,0	27,35	28	1,390
KEY 8X11	8,0	11,0	27,35	28	1,850
KEY 6X13	6,0	13,0	31,42	32	1,400
KEY 8X13	8,0	13,0	31,42	32	1,420
KEY 8X15	8,0	15,0	37,15	38	2,500
KEY 8X16	8,0	16,0	43,08	45	3,100
KEY 10X16	10,0	16,0	43,08	45	4,120

Note: mass volume 7,85 kg/mm³

Technical reading from page 89 to page 90

WOODRUFF KEYS

chiavette unificate

Shims

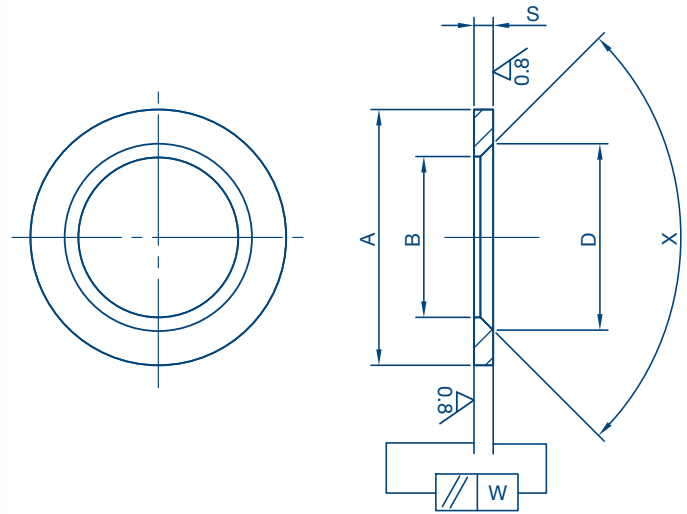

MATERIAL

Hardening and tempering steel or casehardening steel

THICKNESS

from 0,8 mm to 5,00 mm

MACHINING

Blanking, turning, heat treatments, grinding, polishing...

Thickness tolerances up to $\pm 0,01$ mm

Special identification of the components by paint or laser mark available

Our specialization consists in realizing products taken from the client drawings, that need blanking, turning, heat treatments, grinding, polishing, eventual laser mark and/or paint job for recognition of job.

Rod assemblies and special components



In special production, you can get the desired product, thanks to the specialisation of qualified personnel.

This consists in making products to design, which require blanking, milling, heat treatment, grinding, polishing, eventually marking and assembly.

SPECIAL PRODUCTS AND ACCORDING TO DRAWINGS

 **chiavette unificate**

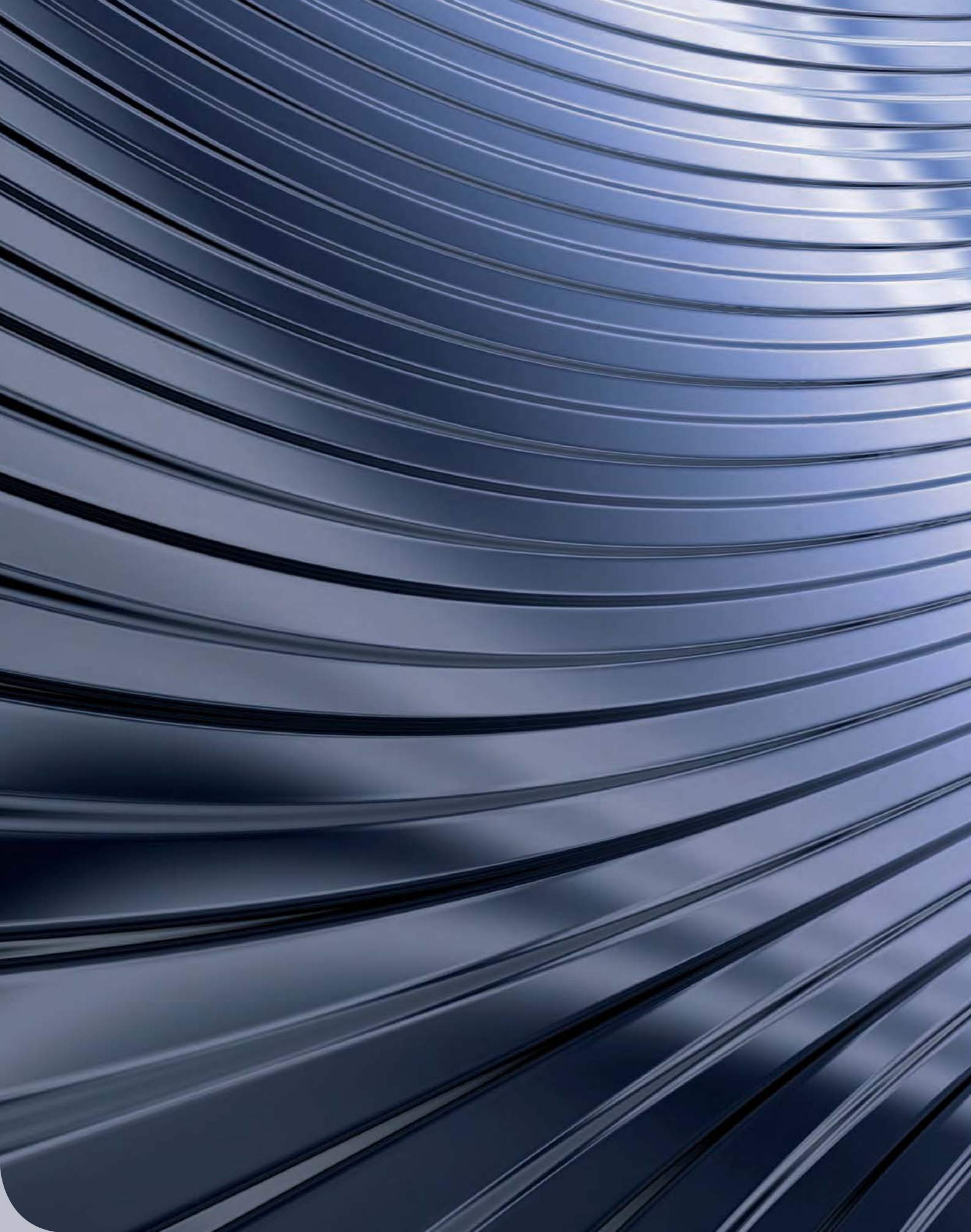

www.chiavette.com

HEADQUARTERS

40069 Zola Predosa - Bologna - Italy - via Giacomo Brodolini, 6/8/10

Tel. +39 051 75.87.67 - Fax +39 051 75.47.80